

(12) UK Patent

(19) GB

(11) 2494312

(13) B

(45) Date of B Publication

17.08.2016

(54) Title of the Invention: **Method and system for managing a parking lot based on intelligent imaging**

(51) INT CL: **G08G 1/14** (2006.01) **G06K 9/00** (2006.01)

(21) Application No: **1219840.4**

(22) Date of Filing: **08.05.2011**

Date Lodged: **05.11.2012**

(30) Priority Data:  
(31) **61332822** (32) **10.05.2010** (33) **US**

(60) Parent of Application No(s)  
**1609843.6** under section 15(9) of the Patents Act 1977

(86) International Application Data:  
**PCT/IB2011/052024 En 08.05.2011**

(87) International Publication Data:  
**WO2011/141861 En 17.11.2011**

(43) Date of Reproduction by UK Office **06.03.2013**

(72) Inventor(s):  
**Daniel Cohen  
Richard Joffe  
Bob Caspe  
Aaron Isaksen  
Ilan Goodman  
Ian Yamey  
Michael Klevansky  
Andrew Crawford  
Konstantyn Prokopenko  
Steven Hartman  
Aurelien Ramondou  
Mark Kudas  
Ezequiel Cura**

(73) Proprietor(s):  
**Park Assist LLC  
575 8th Ave., Suite #1914, New York, NY10018,  
United States of America**

(74) Agent and/or Address for Service:  
**HEPWORTH BROWNE  
15 St Pauls Street, Leeds, LS1 2JG, United Kingdom**

(56) Documents Cited:  
**GB 2430066 A JP 2000057493 A  
US 20100063641 A1 US 20090315738 A1  
US 20090309760 A1 US 20090303079 A1  
US 20090039760 A1 US 20080258935 A1  
US 20080151051 A1 US 20070294147 A1**

(58) Field of Search:  
As for published application 2494312 A viz:  
INT CL **G06K**  
Other: **USPC: 382/104; pubWEST (USPT, PGPB,  
EPAB, JPAB, USOCR); Google (Web)**  
updated as appropriate

Additional Fields  
INT CL **G06K, G07B, G08G, H04N**  
Other: **WPI & EPODOC**

GB  
2494312  
B

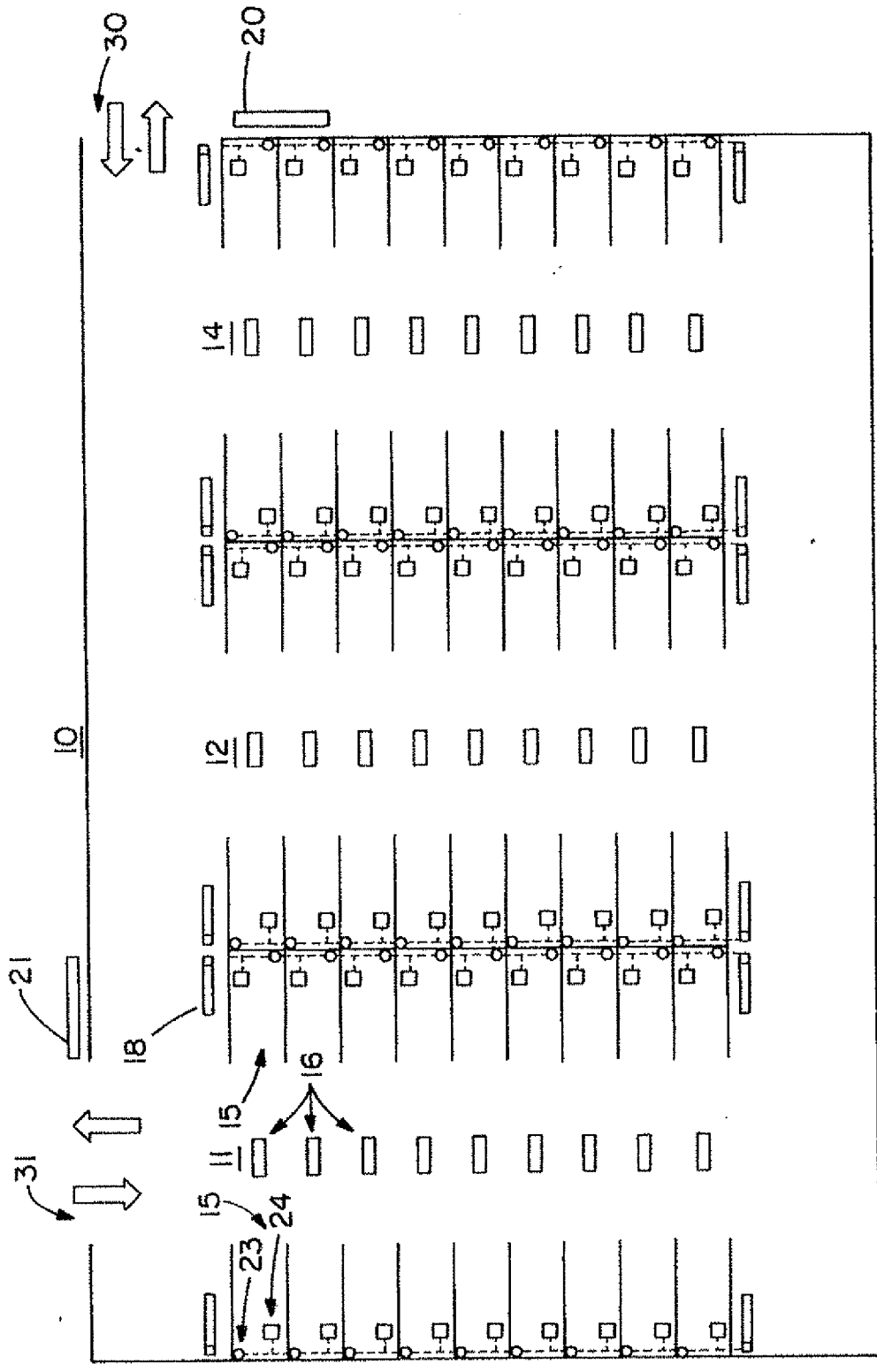

FIG. 1

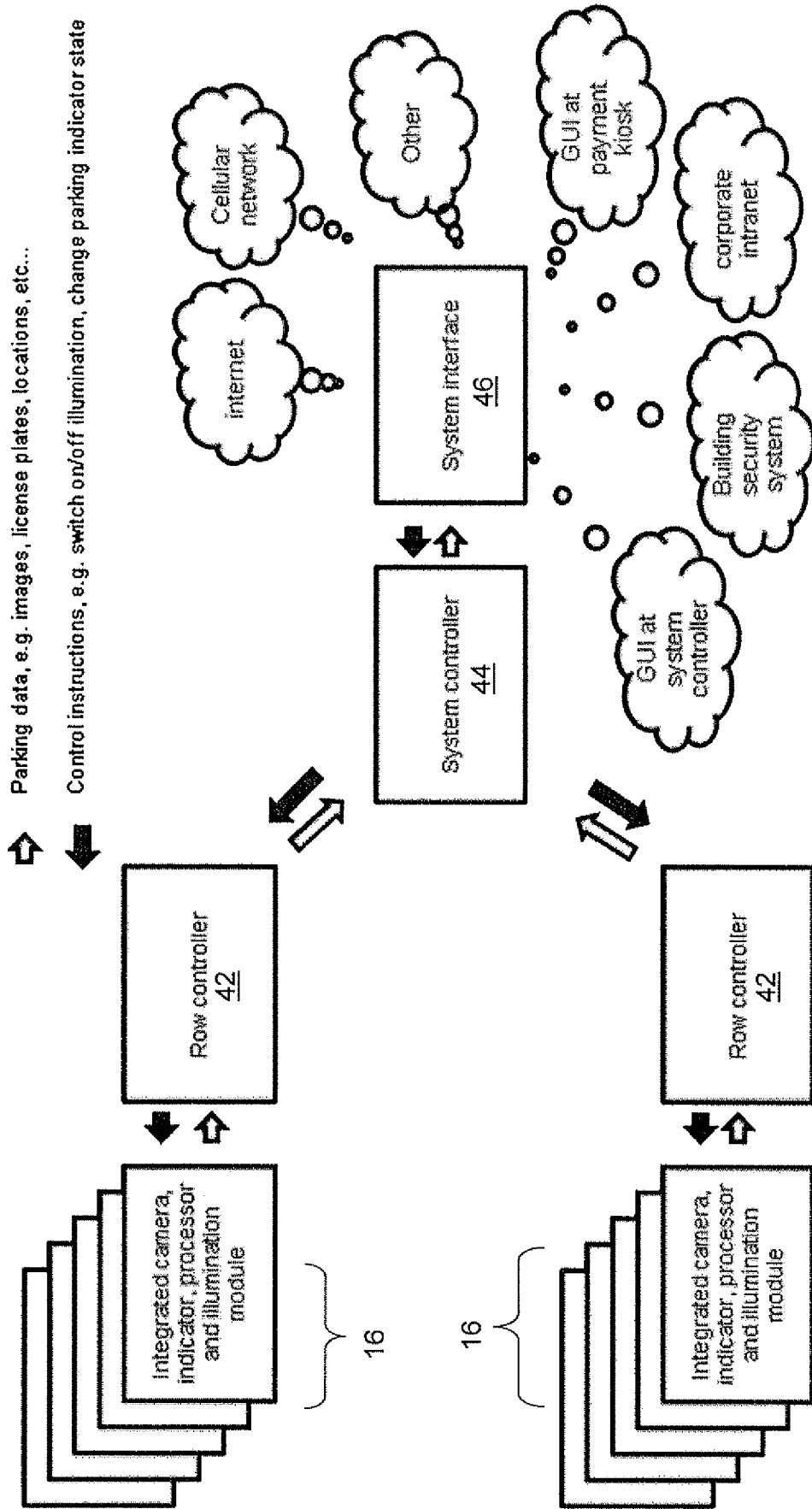

FIGURE 2

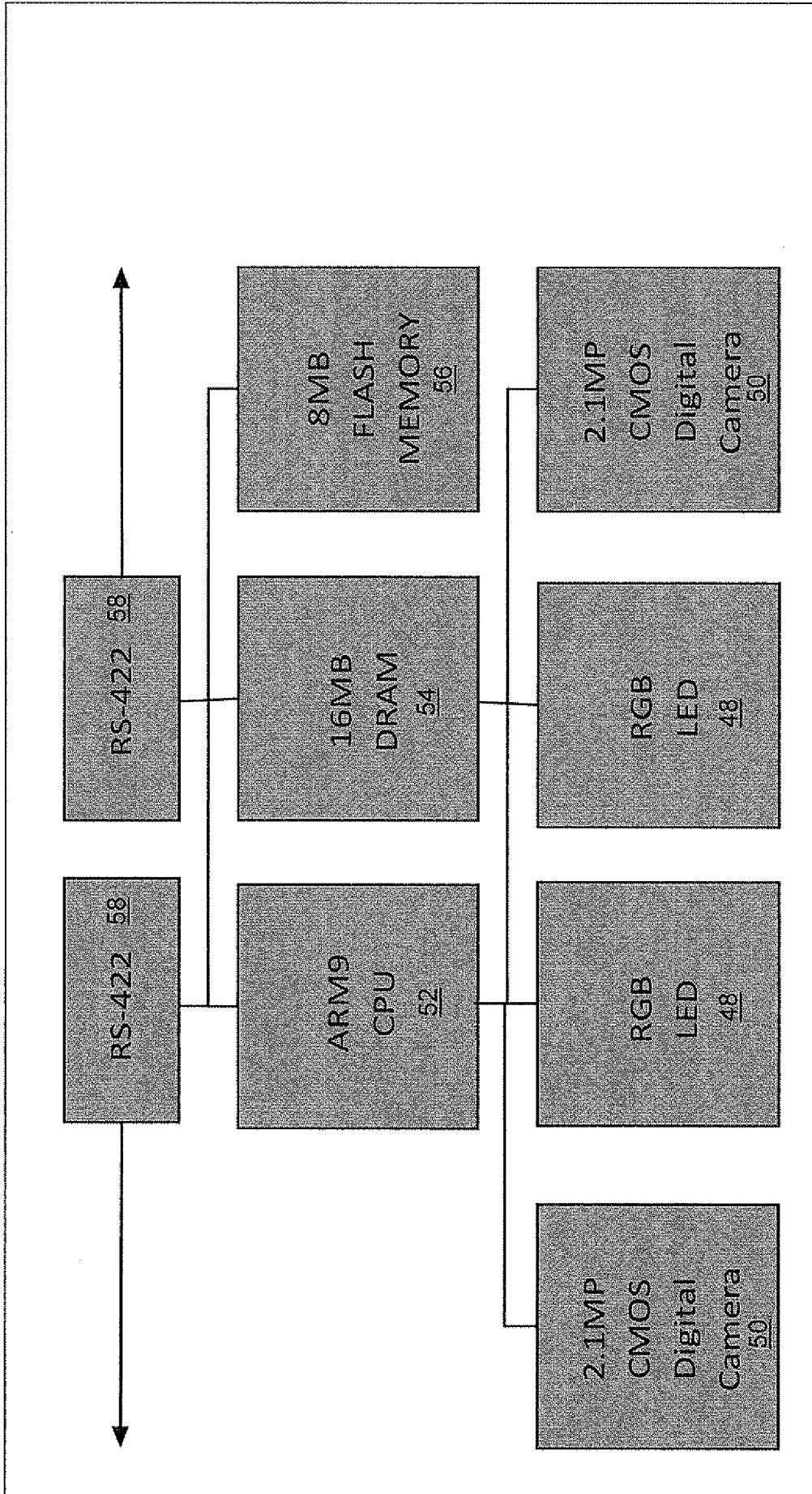

FIGURE 3

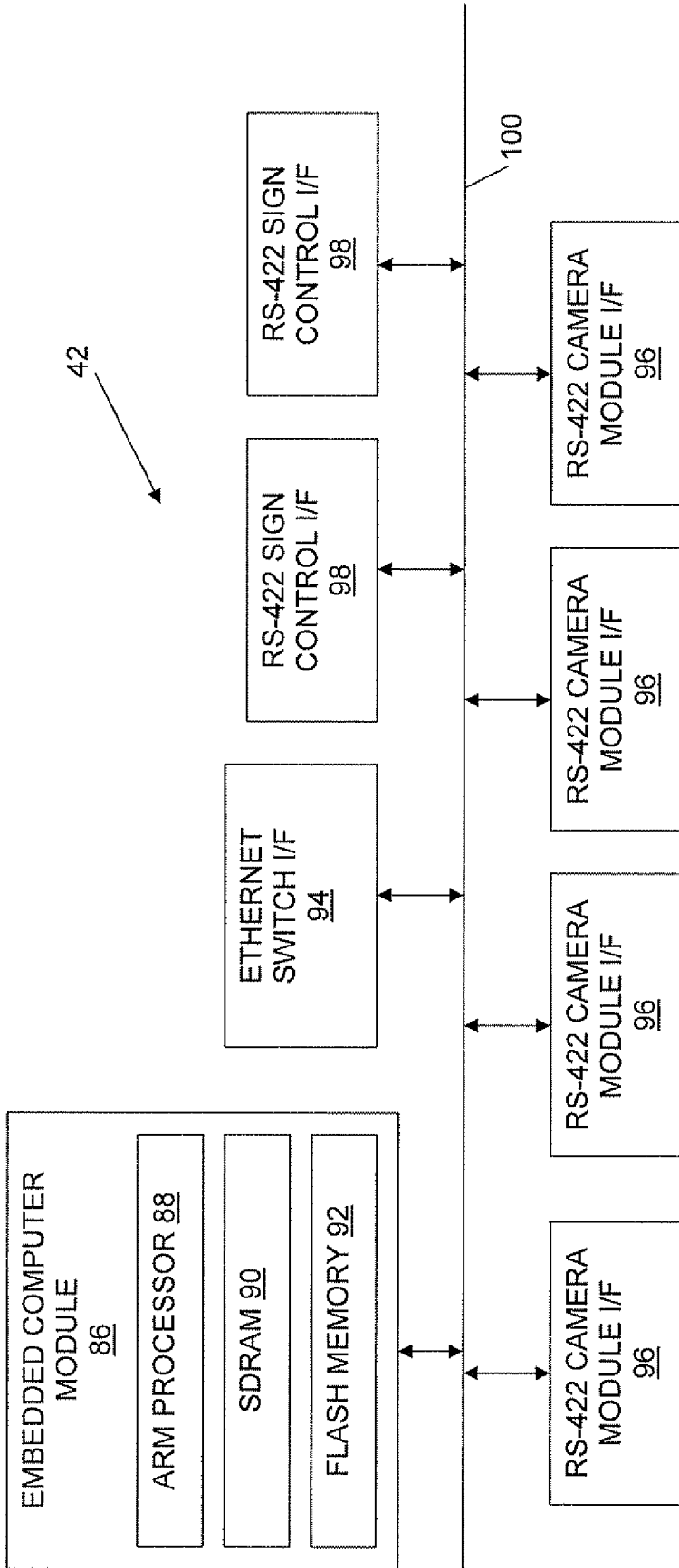

FIGURE 4

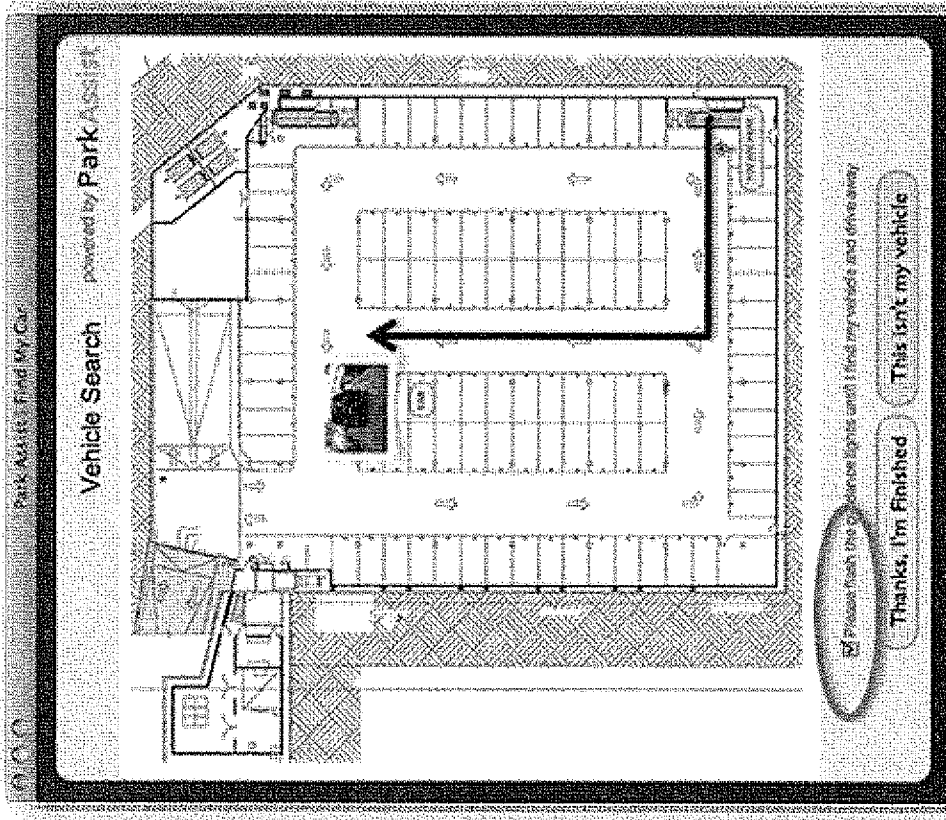

FIGURE 5

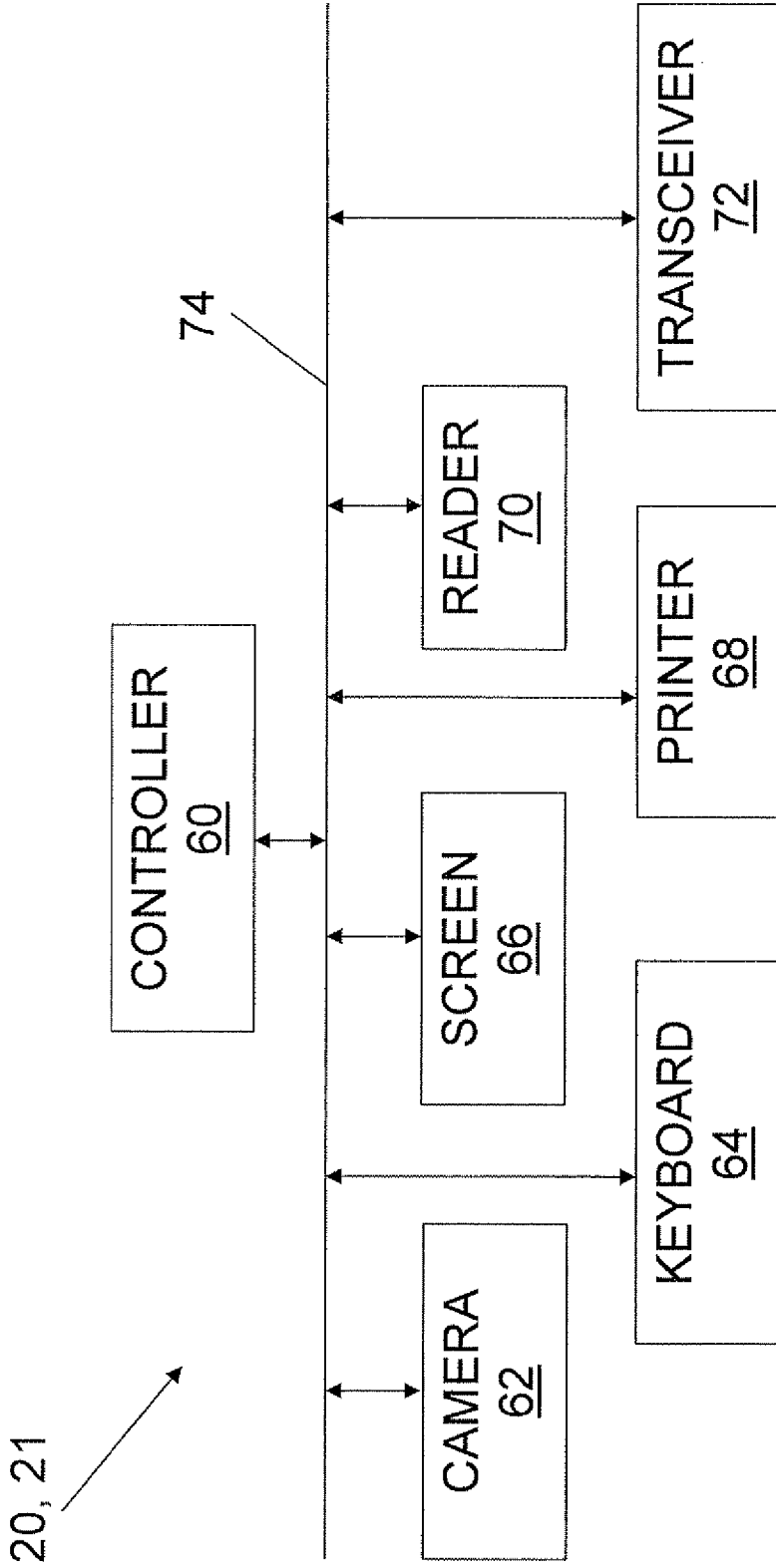

FIGURE 6

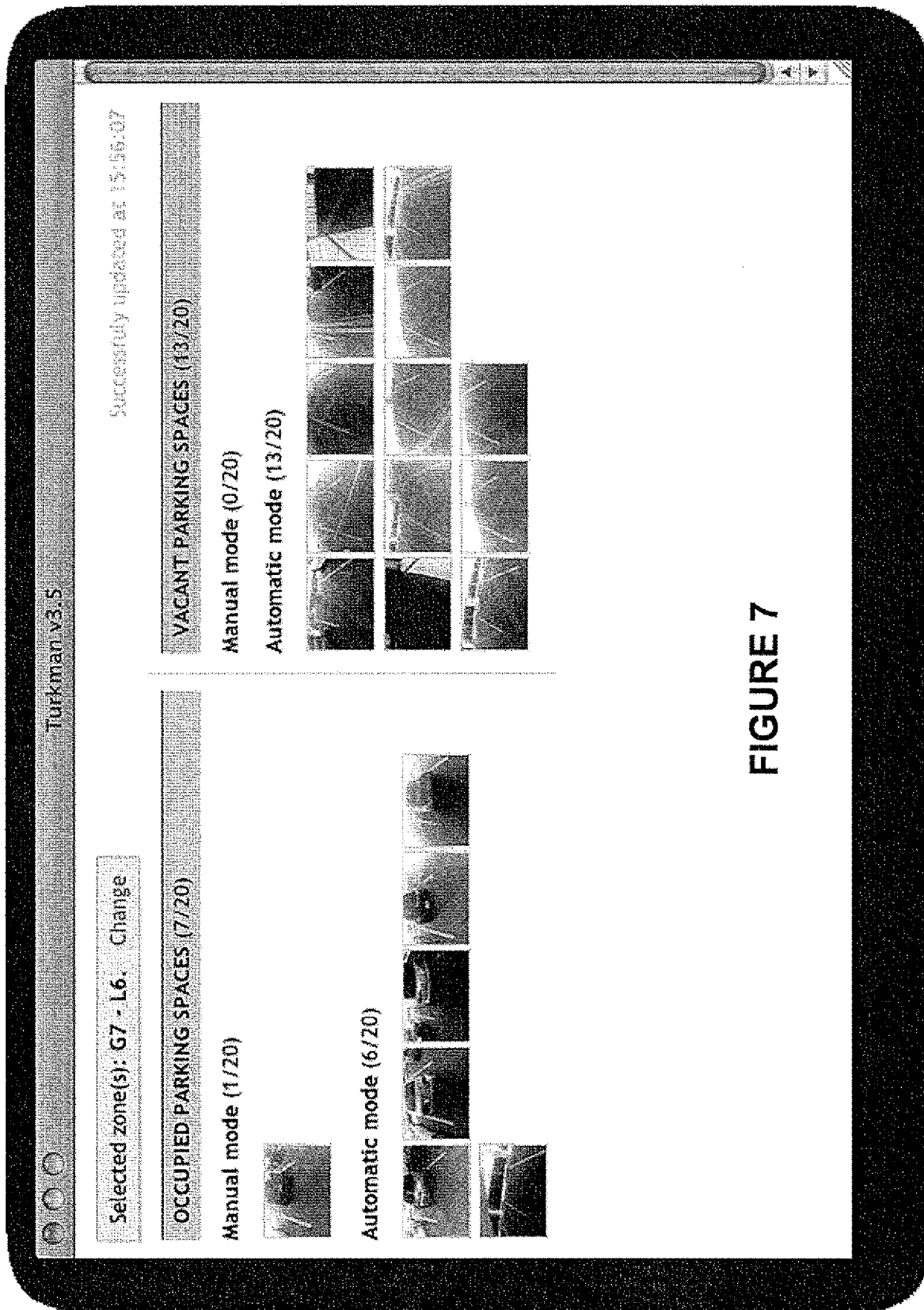

FIGURE 7



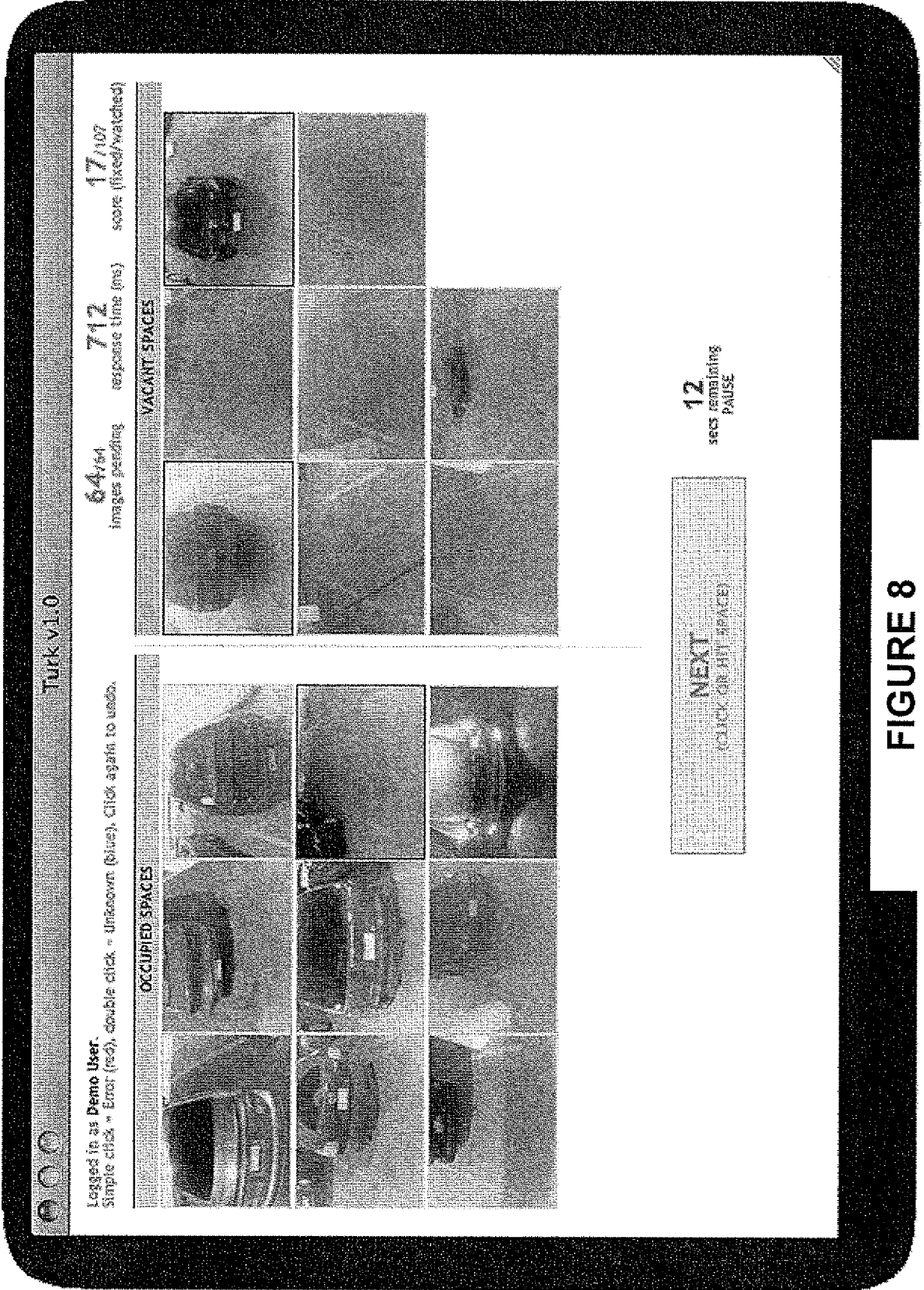

FIGURE 8

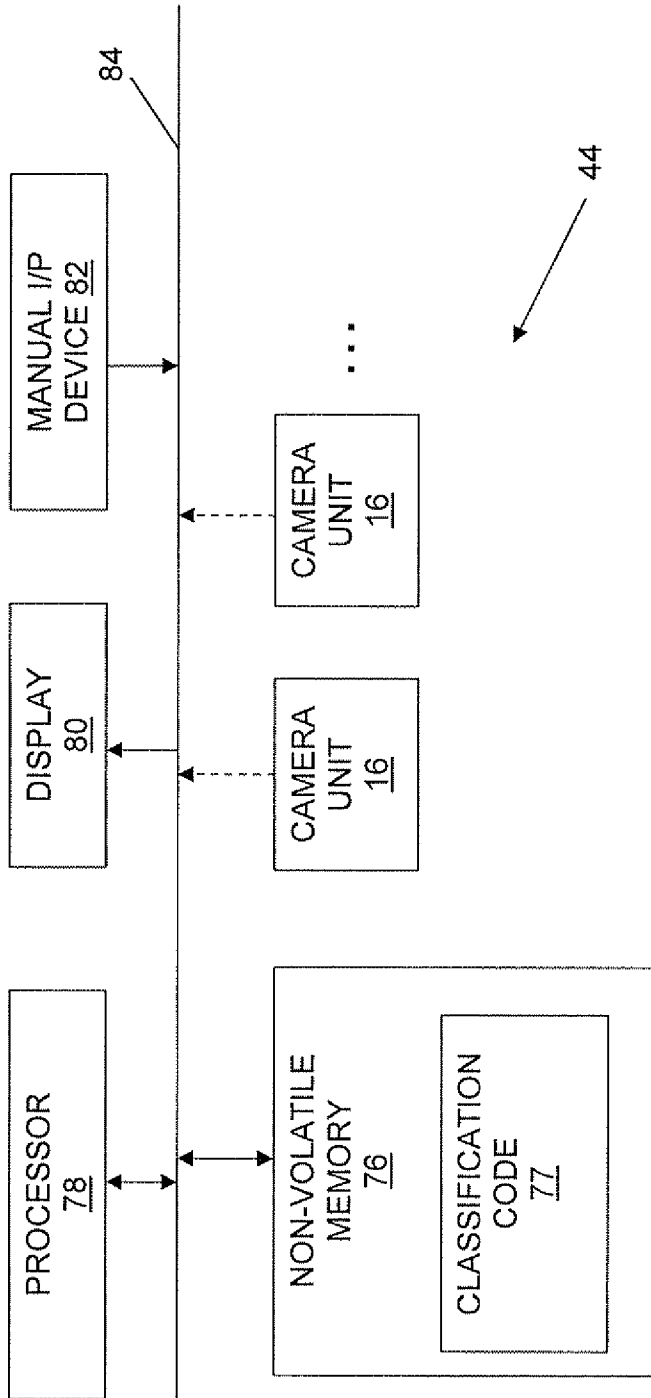

FIGURE 9

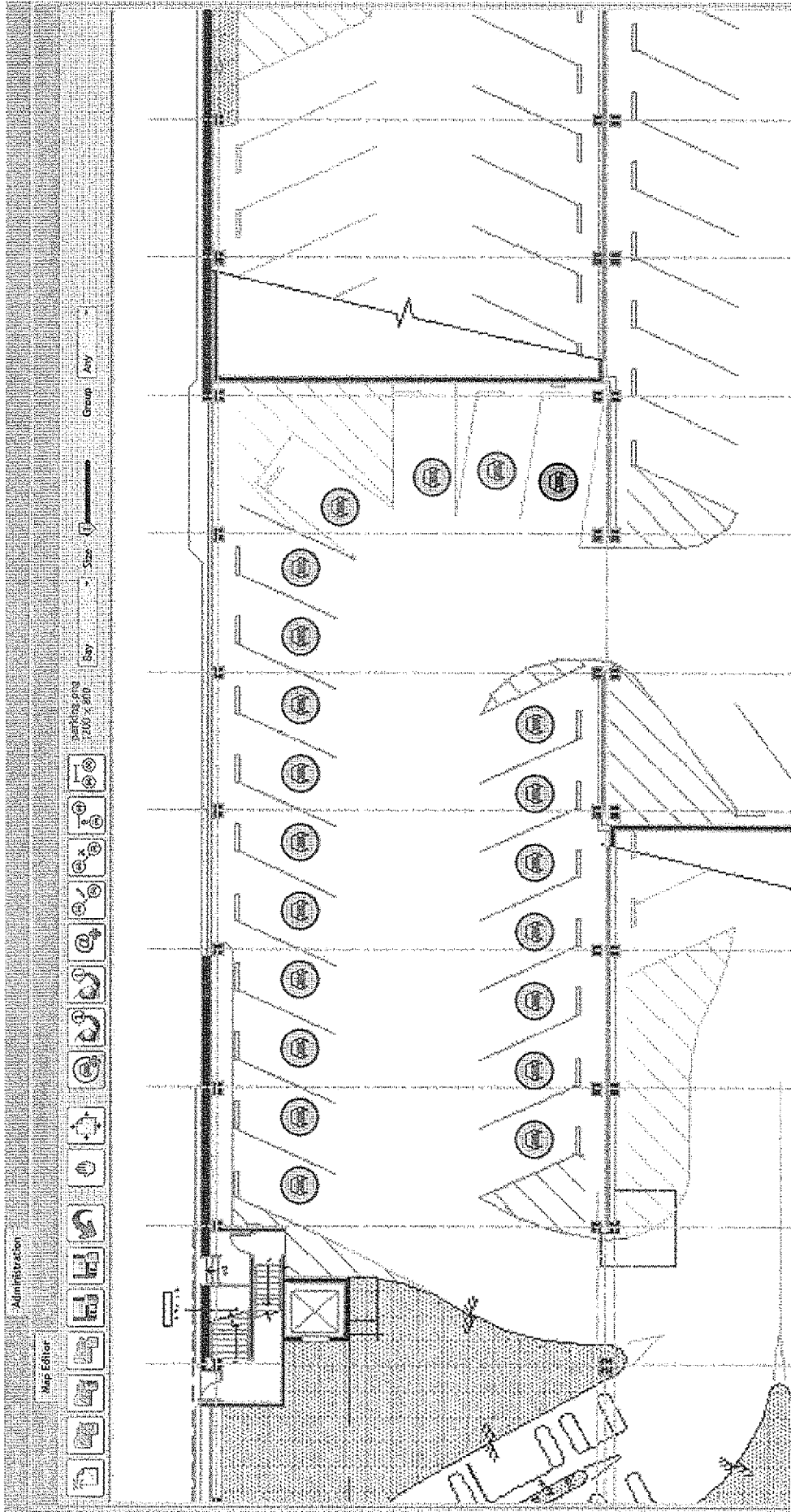
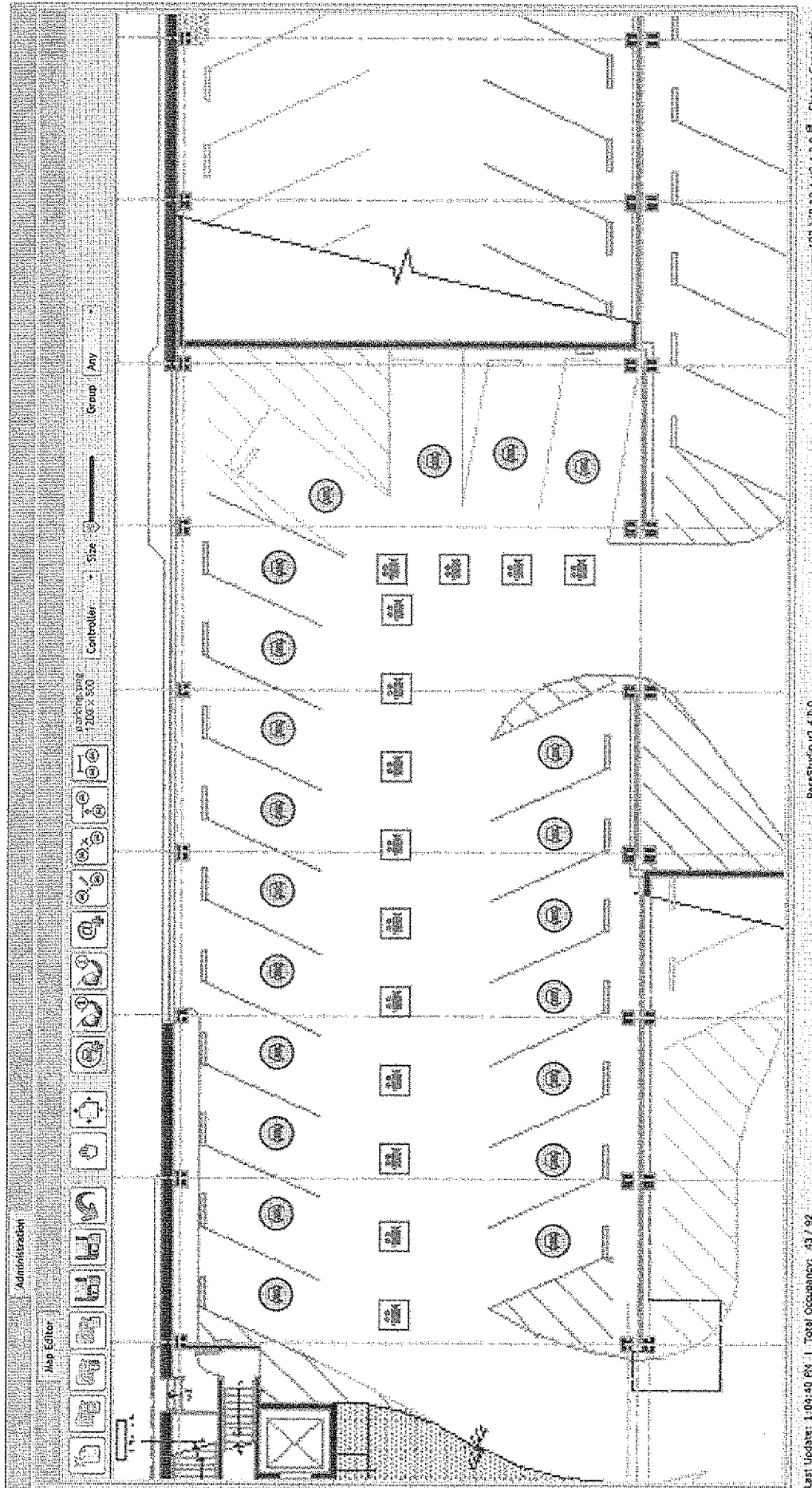

FIGURE 10A



192.168.10.4 v2.4.0.0 Change Connection...

PassStudio v2.4.B.0

Last Update: 1:04:40 PM | Total Occupancy: 43 / 90

FIGURE 10B

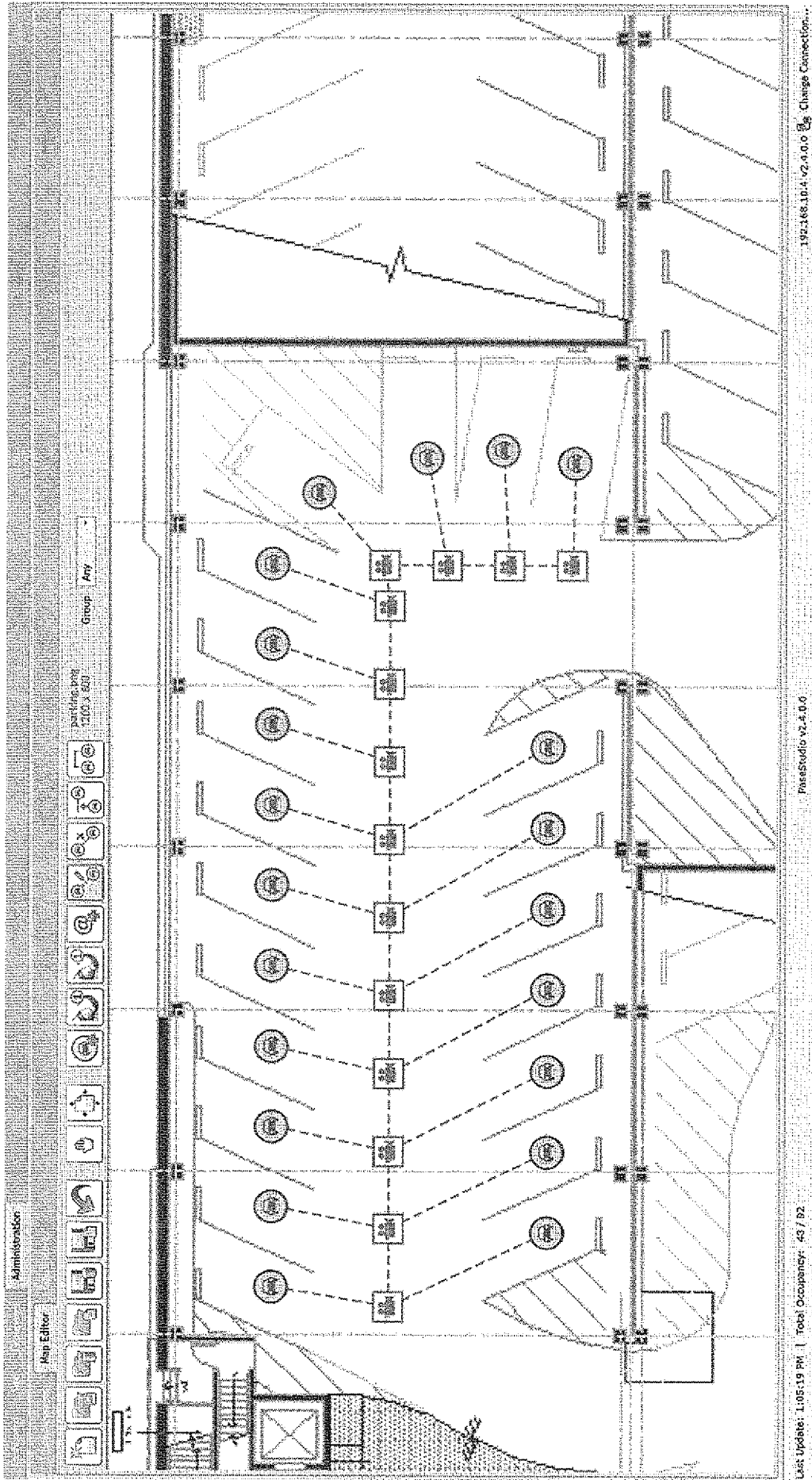

FIGURE 10C

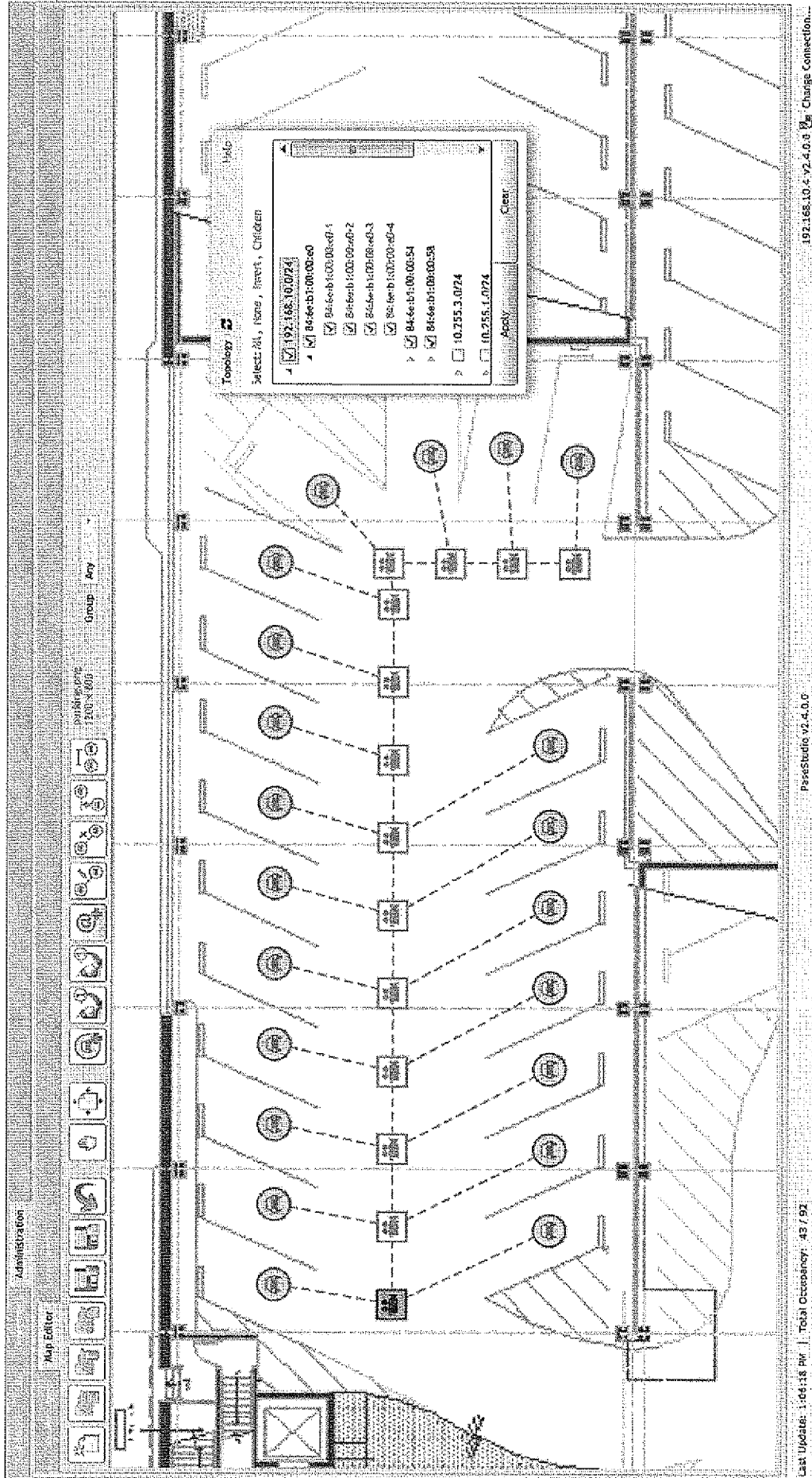
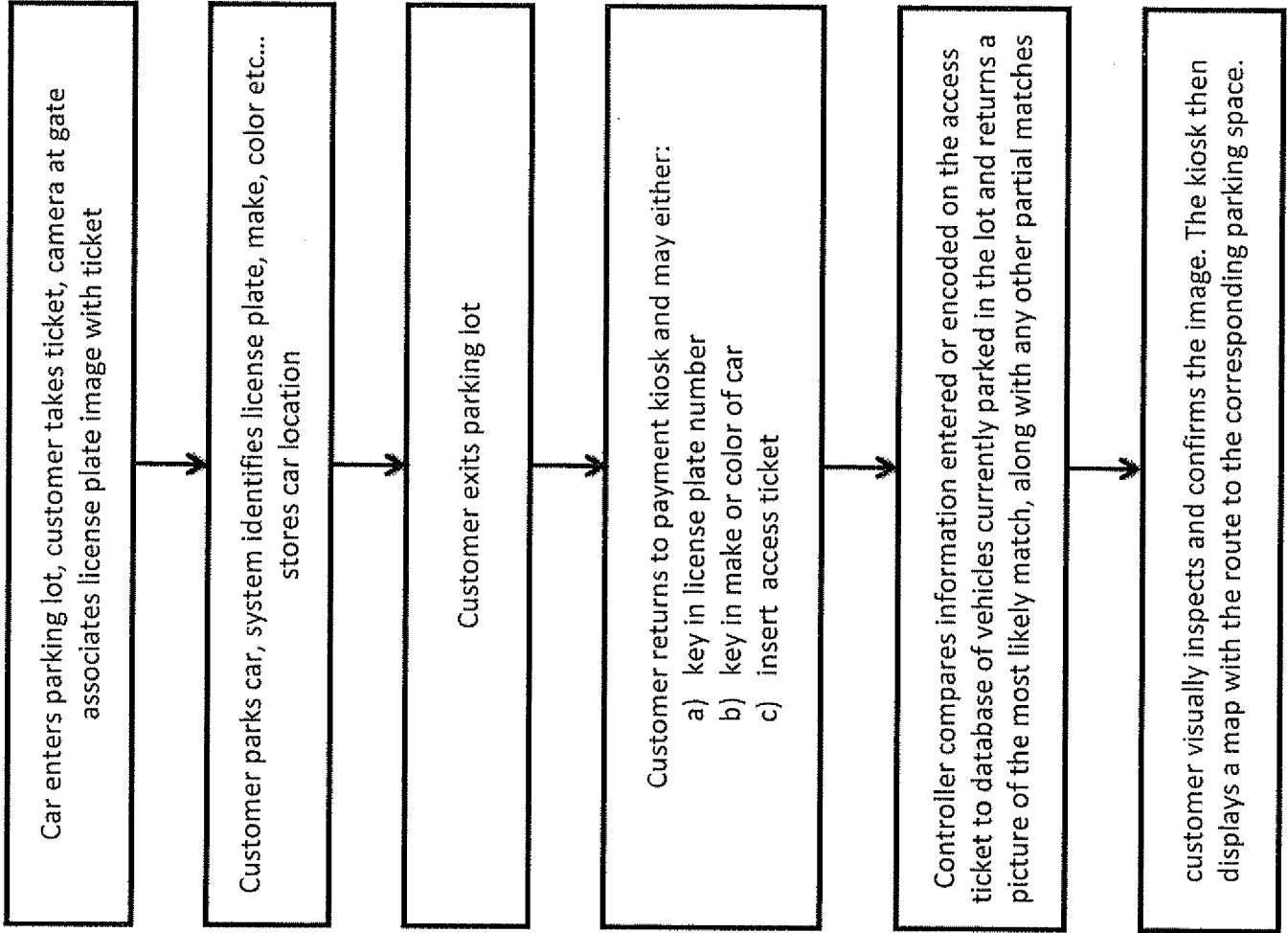

FIGURE 10D

FIGURE 11



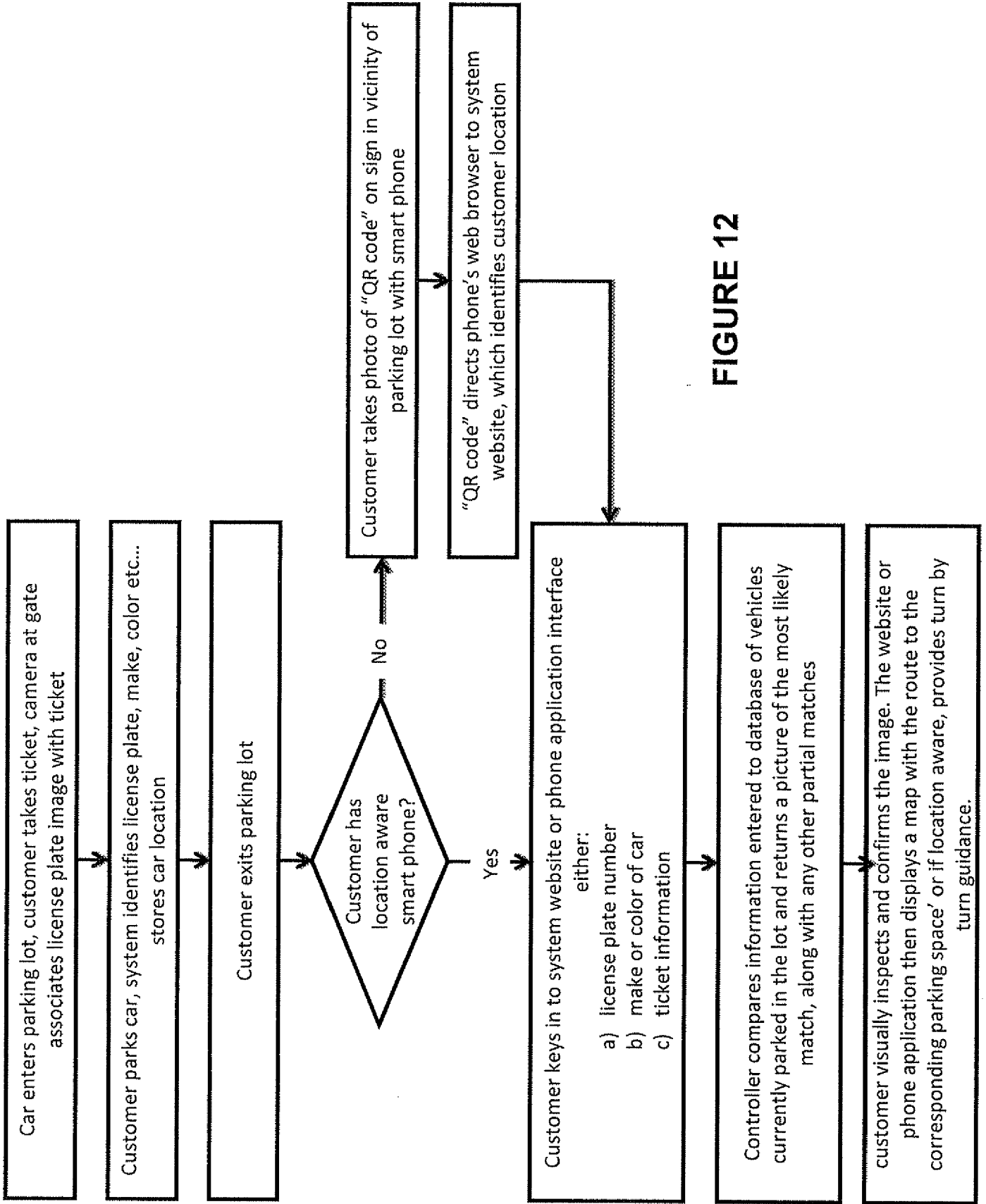

FIGURE 12



# METHOD AND SYSTEM FOR MANAGING A PARKING LOT BASED ON INTELLIGENT IMAGING

## FIELD AND BACKGROUND OF THE INVENTION

5 The present invention relates to the management of a parking lot and, more particularly, to setting up and using a parking lot managing system that relies on intelligent processing of images of the various parking spaces.

A number of methods have been proposed in the past in order to provide customers guidance within a parking lot to quickly find available space. The use of different sensor technologies, such as ultrasonics or image processing is known. These methods may determine occupancy of slots and provide the driver with guidance to available spaces either upon entry to the parking lot or by displays strategically located within the lot. See for example Trajkovic et al., US Patent No. 6,426,708. However, these methods do not provide customers with guidance to find their car when leaving the parking lot. They do not allow the parking lot proprietor the opportunity to preferentially charge the customer according their parking location within the parking lot. Furthermore, these systems do not integrate the parking lot illumination system with the parking control system so as to enable illumination levels or ventilation systems to be controlled based on parking occupancy, reducing energy consumption. In addition, they do not detect the type of object that is stored in the space, determining if it is a car, motorcycle, parking cart, or other object. They also do not recognize unique aspects of the vehicle, such as make, model, color, and license plate, and thus do not allow the opportunity to present targeted advertisements or marketing programs based on such information. They also do not enable remote viewing of individual parking spaces, enabling human intervention to correct mistakes, detect faulty hardware, or provide real-time feedback to improve system accuracy. Finally, they are not integrated with closed circuit security systems, nor do they offer any information about vehicle and passenger security, such as thefts and violent attacks.

## 30 DEFINITIONS

An “occupancy and identity image” is understood herein to mean an image from which either a human operator or a computer equipped with appropriate image processing software can decide whether a parking space is occupied and also can determine the

identity of a vehicle that occupies an occupied parking space. A typical example of such an image is an image from which a license plate detection algorithm can extract a license plate number.

An “occupancy image” is understood herein to mean an image from which either a human operator or a computer equipped with appropriate image processing software can decide whether a parking space is occupied.

An “identification image” is understood herein to mean an image from which either a human operator or a computer equipped with appropriate image processing software can determine the identity of a vehicle given that the image is known to be an image of a vehicle.

The images may be acquired in any convenient wavelength band: infrared, visible or ultraviolet. Usually, the images are RGB images at visible wavelengths.

#### SUMMARY OF THE INVENTION

One objective of the present invention is to provide guidance to customers to efficiently find available parking in a parking lot, and to enable preferential pricing for parking based on location within the parking lot. Therefore, in accordance with a first aspect of the present invention there is provided a method of managing a plurality of parking spaces in accordance with claim 1.

In the following description, systems and methods are described that reduce parking lot energy consumption, and which also improve parking lot security. A determination of the type of object or vehicle that is currently parked in the parking space may be made to determine if it is a car, motorcycle, person, parking cart, or other object. Improved enforcement of parking lot rules and regulations may result from the systems or methods described herein. Through vehicle identification it is possible to administer targeted advertising and loyalty programs. Systems and methods contemplate automatically discovery of the network topology to enable efficient mapping of the sensor locations onto a map of the parking lot, enabling all services already mentioned to be location-based. The systems and method described hereinafter also provide a platform for real-time remote monitoring and human control of the parking system.

The method of the present invention is a method of managing a plurality of parking spaces.

According to a first basic method, one or more occupancy and identity images of the parking spaces are acquired, with each parking space being imaged in at least one of the occupancy and identity images. In response to an inquiry by a customer who has parked a vehicle in one of the parking spaces, the customer is directed to the vehicle, at least in part in accordance with the occupancy and identity image(s) in which the parking space occupied by the vehicle is/are imaged.

Preferably, the occupancy and identity image(s) is/are acquired periodically.

Preferably, the method also includes obtaining an identifier of the vehicle, either before the vehicle is parked or as a part of the inquiry. Examples of such identifiers include license plate numbers and partial or complete visual characterizations such as make and color. One example of an inquiry that provides a vehicle identifier is a typed inquiry that includes the license plate number of the vehicle. The parking space in which the vehicle is parked then is identified, in response to the inquiry, at least in part by comparing the identifier to the occupancy and identity image(s) in which the parking space occupied by the vehicle is/are imaged.

If the identifier of the vehicle is obtained before the vehicle is parked, then the obtaining of the identifier of the vehicle includes acquiring an identification image of the vehicle. Most preferably, the method then includes issuing to the customer a receipt, such as a printed access ticket or a packet that is transmitted wirelessly to a mobile device of the customer, before the customer parks the vehicle. The receipt includes a representation of the identifier.

Preferred modes of directing the customer to the vehicle include displaying a map that shows a route to where the vehicle is parked or issuing navigation instructions, as a printed list or as interactive instructions transmitted wirelessly to a mobile device borne by the customer.

A system for implementing the first basic method includes at least one parking space camera (*e.g.* cameras 50 in the preferred embodiments described below) and a controller. The parking space camera(s) is/are for acquiring the occupancy and identity image(s). The controller, in response to the customer's inquiry, directs the customer to the vehicle at least in part in accordance with the occupancy and identity image(s) in which the parking space occupied by the vehicle is/are imaged. Preferably, the system includes a plurality of such parking space cameras, with each parking space camera acquiring respective one or more occupancy and identity images of one or more respective parking

spaces. Usually, each parking space camera is dedicated to one, two or four specific respective parking spaces.

Preferably, the system also includes an information terminal at which the customer enters the query. Most preferably, the information terminal includes a display mechanism for displaying instructions that direct the customer to the vehicle. Examples of such display mechanisms include a display screen for displaying a map with directions to the parking space, a printer for printing such a map or for printing a list of navigation instructions, and a transceiver for transmitting such instructions interactively to a mobile device borne by the customer as the customer walks to the parking space. Most preferably, the information terminal also includes an input mechanism that the customer uses to input an identifier of the vehicle. A typical example of such an input mechanism is a keyboard at which the customer types the license plate number of the vehicle. In response to the inquiry, the controller identifies the parking space, in which the vehicle is parked, at least in part by comparing the identifier to (one or more of) the occupancy and identity image(s).

Alternatively or additionally, the system also includes a gateway terminal for obtaining an identifier of the vehicle before the customer parks the vehicle in the parking space. In response to the inquiry, the controller identifies the parking space, in which the vehicle is parked, at least in part by comparing the identifier to (one or more of) the occupancy and identity image(s). Most preferably, the gateway terminal includes a mechanism for issuing to the customer a receipt such as an access ticket that includes a representation of the identifier. Also most preferably, the gateway terminal includes an identification camera for acquiring an identification image of the vehicle.

In the preferred embodiments below, entry kiosks 20 and 21 serve both as information terminals and gateway terminals.

According to a second basic method, one or more occupancy images of the parking spaces are acquired, preferably periodically, with each parking space being imaged in at least one of the occupancy images. One or more respective environmental aspects of the parking spaces are controlled at least in part in accordance with the occupancy image(s). Typically, the environmental aspect(s) that is/are controlled is/are illumination and/or ventilation. A corresponding system includes one or more cameras for acquiring the occupancy image(s), a plurality of devices per environmental aspect for controlling the environmental aspect, and a controller that uses the devices to control the environmental aspect(s) at least in part according to the occupancy image(s).

A third basic method starts with acquiring respective occupancy images of the parking spaces. An image classification system automatically designates each occupancy image either “vacant” or “occupied”. The occupancy images are displayed along with their “vacant/occupied” statuses. In response to the display, a human operator decides whether the classifications are correct and corrects the incorrect classifications. Preferably, the image classification system uses a self-modifying classification algorithm, *i.e.*, an algorithm that can be trained to improve the classification accuracy thereof. In response to the corrections by the human operator, the classification system modifies the classification algorithm to be more accurate.

A corresponding system includes one or more cameras for acquiring the occupancy images, a display device for displaying the occupancy images, a memory for storing program code for classifying the occupancy images as either “vacant” or “occupied” and for displaying the occupancy images along with their respective “vacant/occupied” classifications, a processor for executing the code, and an input device that a human operator uses to correct the classifications as displayed on the display device. Preferably, the algorithm that the program code uses to classify the occupancy images is self-modifying. The scope of this system also includes a computer-readable storage medium bearing such computer-readable program code.

A fourth basic method is a method of configuring a plurality of sensors, such as camera units 16 of Figure 1 below, to monitor parking spaces of a plurality of aisles, such as aisles 11, 12 and 14 of Figure 1 below, each of which includes its own respective plurality of parking spaces. Each aisle is provided with two or more sensors. It is intended that each sensor be responsible for monitoring one or more respective parking spaces of the aisle. In each aisle, the sensors are connected operationally to each other in an ordered string. (That the string is ordered means that, with  $N \geq 2$  sensors in the string, the first sensor is connected only to the second sensor, the last sensor is connected only to the next-to-last sensor, and, if  $N > 2$ , sensor  $i$  ( $1 < i < N$ ) is connected only to sensors  $i-1$  and  $i+1$ .) The first camera in each string is the root node of the string. All the root nodes are connected operationally to a central controller such as system controller 44 of the preferred embodiments described below, either directly or indirectly via intermediate devices such as row controllers 42 of the preferred embodiments described below, thereby providing a network of the sensors. The central controller discovers the topology of the network. Only one sensor of each string (preferably the root node sensor) is mapped to the respective

parking space(s) that that sensor is to monitor. The topology is used to map the other sensors of each string to their respective parking spaces.

A corresponding system includes, for each aisle, a respective plurality of sensors operationally connected to each other in an ordered string with a first sensor of the string being a root node of the string, and a controller to which all the root nodes are operationally connected, so that the controller and the strings form a network. The controller is operative to discover the topology of the network, to present a user interface for mapping only one sensor of each string to its respective parking space(s), and to use the topology to map the rest of the sensors to their respective parking spaces. The scope of this system also includes a computer-readable storage medium bearing computer-readable program code that the controller executes to accomplish those ends.

The controllers of the systems may be local to the parking lot that includes the managed parking spaces or, as illustrated in Figure 2 below, may be distributed among two or more sites with the various components of the controllers communicating with each other via a network such as the Internet.

#### BRIEF DESCRIPTION OF THE DRAWINGS

Various embodiments are herein described, by way of example only, with reference to the accompanying drawings, wherein:

FIG. 1 is a plan view of a parking lot;

FIG. 2 is a schematic illustration of a system of the present invention;

FIG. 3 is a block diagram of a camera unit of FIG. 2;

FIG. 4 is a block diagram of a row controller of FIG. 2;

FIG. 5 shows screen captures that illustrate the “find your car” feature;

FIG. 6 is a partial block diagram of an entry kiosk of FIG. 1;

FIGs. 7 and 8 shows web page user interfaces for manual tuning of the automatic vehicle detection algorithm;

FIG. 9 is a partial block diagram of a system controller that is configured to support interactive correction of automatic occupancy detection;

FIGs. 10A-10C illustrate mapping of camera units to their locations following camera unit network topology discovery;

FIGs. 11 and 12 are flowcharts of the “find your car” feature.

## DESCRIPTION OF THE PREFERRED EMBODIMENTS

The principles and operation of a parking lot according to the present invention may be better understood with reference to the drawings and the accompanying description.

Referring now to the drawings, Figure 1 is a plan view of the interior of an exemplary enclosed parking lot **10** that is managed according to the principles of the present invention. Parking lot **10** includes three aisles **11**, **12** and **14**, each aisle including two rows of parking spaces **15**. Each pair of parking spaces is monitored by an associated camera unit **16**. Each parking space **15** is provided with its own ventilation vent **23** and its own lighting fixture **24**, in the ceiling of parking lot **10**. Each row of parking spaces **15** has two row displays **18** at either end. Each entrance **30**, **31** of parking lot **10** has adjacent to it an entry kiosk **20**, **21**.

Figure 2 illustrates an exemplary embodiment of a system of the current invention. The system includes camera units **16**, row controllers **42**, a system controller **44** and a system user interface **46**. System user interface **46** may be connected to multiple additional external systems as shown in Figure 2.

In one embodiment of the system of Figure 2, high resolution, low noise, CMOS digital camera technology is used for the purpose of monitoring every parking space **15**. Images that are collected are processed within the individual camera module **16**. Images, license plate data or occupancy data or any combination of the three can be passed through row controllers **42** to the central system controller **44** for actual live inspection down to the individual space **15** from the central station.

Remote access to the central station through the Internet can provide control and access including live images from any of up to thousands of cameras throughout a parking garage. Each unit **16** is designed to monitor one or more parking spaces **15** through directly detecting occupancy in the specific parking space **15**. In the example of Figure 1, each unit **16** monitors two parking spaces **15**. Furthermore, an energy efficient multicolor LED indicator within unit **16** may be used to indicate the occupancy status of that space **15**. For example, a green light may indicate the space **15** is vacant and available for general parking, a blue light may indicate that space **15** is vacant and available for handicapped parking only, and a red light that the space **15** is occupied. In addition to or in place of illumination fixtures **24**, energy efficient LED area illumination can also be incorporated into unit **16**, with the illumination via units **16** and/or via fixtures **24** controlled by system

controller **44** on the basis of local occupancy levels, conserving energy when occupancy levels are low.

Digital scoreboard signs, such as row displays **18**, showing the number of vacant spaces **15** in a particular physical area of the parking lot such as the rows of aisles **11**, **12** and **14**, can be updated by system controller **44** directly, or via row controllers **42**.

In one specific embodiment, the system configuration provides centralized access and control down to the individual space **15** level. System controller **44** connects to up to 512 individual row controllers **42** over an extended range Ethernet CAT5e network. Each row controller **42** can be attached to up to 4 rows of 128 individual camera units **16** per row, for a total of 512 cameras per row controller **42**. Each camera unit **16** can monitor one or more parking spaces **15**, either on opposing sides of the camera unit **16** or in side by side parking bays **15**. Thus a single system of the present invention can monitor and control up to one million individual parking spaces **15**.

Figure 3 is a high level block diagram of a camera unit **16**. Camera unit **16** is used to detect, identify and indicate the occupancy of a garage parking space **15**.

Each camera unit **16** includes:

- high intensity red, green, and blue LED indicators **48** with diffuser;
- two high resolution, high sensitivity CMOS multi-megapixel digital cameras **50**;
- one or more 400MHz ARM9 processor **52**, available from ARM Ltd. of Cambridge GB, with SDRAM **54** and flash memory **56**;
- two 10Mbyte/second RS-422 serial ports **58** for daisy chain installation (or 3-port Ethernet switch);
- optional LPR (License Plate Recognition) software in flash memory **56**.

Row controller **42** attaches to system controller **44** through extended range CAT5e Ethernet. Each row controller can control up to 4 rows of 128 dual camera modules **16** per row. Because each camera module **16** can monitor multiple spaces, a row controller **42** can monitor more than 1024 parking spaces (in two opposing rows).

Each row controller **42** can be used to control multiple independent signs **18** through two independent RS-422 interfaces.

Figure 4 is a high-level block diagram of a row controller **42**. Each row controller **42** includes:

- embedded computer module **86** with ARM processor **88**, SDRAM **90** and flash memory **92**;



- ethernet switch interface **94**;
- up to 4 RS-422 camera module interfaces **96**;
- up to 2 sign control interfaces **98**.

These components communicate with each other via a bus **100**.

5 System controller **44** is a desktop or server grade computer that monitors the entire system and provides a user interface **46** to other external systems that can connect to the parking system. The system is designed in a way that the parking lot signs **18**, row controllers **42**, and camera units **16** can run even if the system controller **46** is unavailable.

10 In another exemplary embodiment, camera modules **16** communicate via Ethernet through an on-board three-port Ethernet switch such as the Micrel KSZ8873MLL available from Micrel, San Jose CA, USA. System controller **44** can then be connected directly to camera units **16**, without the intervening row controllers **42**. Standard network components such as routers and switches can be used to extend the network in a star topology across any physical layout. In that case, the number of camera units **16** per row is effectively  
15 unlimited.

In another exemplary embodiment, peripherals such as digital scoreboard signs **18** are connected to the same Ethernet network, either directly or via Serial-to-Ethernet conversion, and are updated through the network by system controller **44** or by row controllers **42**.

20 In another exemplary embodiment, camera units **16**, which may be serial or Ethernet based, are mounted in the center of the driving lane and have two cameras **50**, one per side, to monitor bays on opposite sides of the lane. If either of the two spaces **15** is vacant, then LED indicator **48** is turned green to show a vacant regular space and blue to show a vacant handicapped space. If both spaces **15** are occupied, LED indicator **48** is  
25 turned red.

In another exemplary embodiment, each camera **50** is aimed such that two adjacent parking spaces **15** are visible in its field of view, so that the camera unit **16** captures information about up to four spaces **15**. In that case, if at least one of four (or one of three, or one of two) spaces **15** is vacant, LED indicator **48** is turned green to show a vacant  
30 regular space and blue to show a vacant handicapped space. If all spaces **15** are occupied, LED indicator **48** is turned red. This architecture can be further embellished to include  $N$  spaces per camera **48** (and thus  $2*N$  spaces per unit **16**), provided all  $N$  spaces are visible in

the field of view of camera 48. Wide-angle lenses can be used to increase the field of view of camera 48.

One preferred aspect of the system is the ability to automatically determine the network topology and map camera units 16 physically onto a map of the parking structure.

5 This can be achieved in a variety of ways, depending on the specific embodiment of the invention:

#### 1. Serial communication - Packet decoding method

For serial communicating camera units 16, each packet gets retransmitted by a camera unit 16 if destination address is somewhere down the row. Each packet includes a header with several fields necessary for discovery of the location of a camera unit 16:

- “original address”;
- “source address”;
- “destination address”.

When packet is received, camera unit 16 checks if a location was assigned. If not, the following applies:

- Camera unit 16 checks for a source address. The source address is the address of row controller 42 or the first neighbor on the way to the row controller 42. IF ID is 0, then camera unit 16 is the first on the row.
- Camera unit 16 increments the source address of the packet and assigns its own ID.
- Camera unit 16 also marks the port where packet was received as HOME port and the other as AWAY port. HOME port is the port towards the row controller 42.
- After location is assigned, camera unit 16 uses this ID to mark all outgoing packets in the “source address” field.

#### 2. Ethernet sorting version 1 – Server initiated Topology Discovery and Sorting algorithm.

This method assumes that the network of camera units 16 is organized into several IP subnets, each with one or more daisy-chain strings of nodes (star topology).

1. System controller 44 sends “Get Version” request to each IP in the IP network group to find out number of camera units 16 and their IP/MAC addresses.
2. System controller 44 assembles a list of all active camera units 16 in the network group.

3. System controller **44** issues request to each camera unit **16** to ping the assembled list of camera units **16** in order to populate MAC table of its Ethernet switch.
4. System controller **44** requests MAC tables from all camera units **16**.
5. System controller **44** performs topology discovery and sorting algorithm as follows:

Topology Discovery Algorithm:

- System controller **44** finds end camera units **16**. End camera units **16** do not have any other camera unit **16** MAC addresses on one of the ports of their Ethernet switch.
- System controller **44** chooses randomly a single end camera unit **16**.
- System controller **44** builds a route by selecting another end camera unit **16** and checking all camera units' **16** MAC tables. A camera unit **16** belongs to this route if both end camera unit **16** MACs are located on separate ports of the camera unit's **16** MAC table. Each camera unit **16** is checked and route is built as a list.
- System controller **44** finds the first end camera unit **16** by checking the table for either the System controller's **44** MAC or the router's MAC. The First System controller's **44** MAC should be located on the same port with the System controller's **44** MAC.

Sorting Algorithm

- System controller **44** picks a random camera unit **16** in a middle of the discovered route.
- System controller **44** moves all camera unit **16** of the route on either side of the selected camera unit **16** based on a MAC location in the selected camera unit **16** MAC table. For example: camera unit **16** that appeared on port 0 are moved to the left of the selected camera unit **16**, and the rest are moved to the right. The selected camera unit **16** becomes "top" of the two branch tree.
- System controller **44** chooses right branch first and walks through the camera unit **16** applying a sliding window of three camera unit **16** including the top camera unit **16**. System Controller **44** arranges the three camera unit **16** between each other.

- System controller **44** slides the window down by one camera unit **16** and performs arrangement again until the bottom is reached.
- System controller **44** slides the window again from the top until no camera unit **16** are shifted in this branch.
- 5     • The left branch is sorted the same way. This can be done in parallel with the right branch in two separate threads. Sorting of the branches is an independent task.
- System controller **44** builds routes for remaining end camera units **16** and repeats sorting for each branch.
- 10    • Every time routes cross on a camera unit **16**, system controller **44** marks camera unit **16** as joint camera unit **16**.
- At the end we've got a sorted tree which can have any number of branches and cross-branches.

### 3. Ethernet Sorting V2 – Camera unit 16 initiated Topology Discovery.

15       This sorting method includes a requirement that the network avoid branching, and that each string of camera units **16** exists on a single router entry. This method invokes two components: TDD: Topology Discovery Daemon – a program running constantly in the background on the ARM processor of each camera unit **16**, and a SensorIdentity library which is called on demand by the main application running on the camera unit **16** to find  
20    out its location at any time. The TDD daemon's main responsibility is to refresh all MAC tables in the string.

- TDD is called by a watchdog agent on the TDD's camera unit **16** every 30 seconds.
- TDD checks if its camera unit **16** is the last camera unit **16** in the string.  
25       TDD gets MAC table from the camera unit **16** Ethernet Switch and checks if there are no camera unit **16** MAC entries on one of the ports.
- If the TDD's camera unit **16** determines that it is the last camera unit **16** in the string:
  - TDD gets broadcast address from socket control functions.
  - 30     • TDD sends ping for a single packet on the broadcast address. This ensures that each camera unit **16** in the string receives the ping

packet and that the MAC table of the Ethernet switch of each camera unit 16 in the string gets populated.

- TDD exits.

SensorIdentity library is called by the main application running on the camera unit 5 16 to get its location ID in real-time. SensorIdentity library performs the following actions:

- Gets gateway address from network tools (socket control functions).
- Finds MAC address of a gateway by ARPing the address
- Finds which port of the MAC table includes the gateway MAC.
- Calculates the number of camera unit 16 on the same port.
- 10 • The camera unit 16 location ID is the calculated number + 1.

#### Vehicle and Event Detection Algorithms

In one embodiment, the car detection algorithms run inside each camera unit 16, and work even if the connection to the row controller 42 is missing. Periodically, for example several times a second, an image is captured by the internal CMOS sensor of the 15 camera unit 16 and is transmitted to the SDRAM 54 of the unit 16. ARM processor 52 in unit 16 then examines the image, calculating several metrics based on the content of the current image. These metrics are fed into a classification routine which has been previously trained on several thousand car and empty space images. The output of this classifier determines if a car is in the space 15 or not. Based on the the values of the 20 metrics, different types of vehicles and objects can be determined. Any classification routine or machine learning algorithm can be used; some common algorithms in the literature include Classification and Regression Trees, Support Vector Machines, and Artificial Neural Networks.

In one extension to the method described above, the metrics that are computed can 25 themselves be learned from training data, using a variety of methods known in the art such as Kernel Methods, Principal Components Analysis, Independent Component Analysis, Feature Detection Methods, etc.

In a second extension, the determination of parking space occupancy can take into account time and historical activity. For example, using methods of background modeling, 30 the detection routine can learn a model of the empty space over time and compare new images to the learned model to determine if a vehicle has entered or exited. Another implementation could use a change detection algorithm to determine when an event has occurred in the parking space (*i.e.* a car has entered or departed), by computing a running

average or variance of the image or some other aspect or aspects of the image, and comparing the aspect of the image to the same aspect of each other image frame.

In a third extension, both of the above methods could be combined to provide a more accurate and robust method to detect vehicles in the parking space. For example, the output of the classifier could be used as feedback for the modeling routine to refine or prune its model. This could be further refined by using the “confidence” value of the classification output. In addition, the change detector could be used to bias the decision, depending on the current state. Moreover, the combination of methods can be tuned to trade off between false alarms (saying the space is occupied when it is really empty) and misses (saying the space is empty when it is really occupied), depending on the operator’s preference.

In a fourth extension, a complete time- and history- dependent Markov model of the parking space can be constructed and updated in real-time. For example, at each time step (usually the acquisition time of a single image), the likelihood of the space being occupied is a function of the previous state, the current image metrics, the previous  $n$  image metrics, and the current time. This function can be optimized offline from training images, or can be learned and updated in real time.

The decision space of any or all of these algorithms can be expanded to include other events or characteristics to be detected, such as vehicle make, model, class, and color, as well as security events such as suspicious activity and physical violence.

#### License Plate Detection Algorithm

License plate detection by a camera unit 16 occurs in two stages. First, the image patch containing the license plate can be found using a variety of methods, such as template matching, or edge detection, looking for rectangular edges in the image and finding the most likely candidates for a license plate, based on the relative location and aspect ratio of the license plate. The license plate image is then processed by an Optical Character Recognition (OCR) routine that determines the values of the text and symbols contained in the license plate. This information is then transferred to system controller 44 (directly, or via the row controller 42) for storage and use.

In alternative embodiments, any or all of these algorithms run in the row controllers 42, in the system controller 44, or in the Ethernet level, or in a combination thereof. For example, in one such embodiment a camera unit 16 detects a vehicle entering a parking space and notifies system controller 44. System Controller 44 then requests a high

resolution image from that camera unit 16. When system controller 44 receives the image from the camera unit 16, system controller 44 processes the image to extract the license plate image and presents the extracted license plate image to an OCR module for text extraction.

## Additional Features

### Find Your Car Feature

The system captures and analyses license plates and their location to the individual spaces 15 in parking lot 10. A customer enters his/her license plate number at the one of the entry kiosks 20 or 21, to locate the exact space at which the vehicle is parked. Figure 5 shows exemplary screen captures, from the display screen of an entry kiosk such as entry kiosks 20 and 21, of the process. The customer may either key in the license plate number, make or color of car. Alternately, in an embodiment in which a camera similar to camera 50 in the relevant entry kiosk 20 or 21 captured the customer's license plate number when the customer's vehicle entered parking lot 10 and encoded the license plate number in the access ticket issued by the entry kiosk, the customer inserts the access ticket into the entry kiosk, which reads the encoded license plate number. System controller 44 then compares the information entered or encoded on the access ticket to its database of vehicles currently parked in the lot, and returns a picture of the most likely match, along with any other partial matches, as shown in the left screen capture of Figure 5. The customer can then visually inspect and confirm the image. The kiosk then displays and/or prints a map with the route to the corresponding parking space, as shown in the right screen capture of Figure 5. Figure 11 shows a flowchart of this embodiment of the "find your car" feature.

In an alternative embodiment, the customer may use his/her smart phone or similar mobile device instead of a kiosk. For example, the customer could take a picture of a "QR code" printed on a sign near the parking lot, which will direct the phone's web browser to a website where the customer can enter the vehicle information as in the kiosk method. Each QR code can be associated with a specific spatial location, allowing the system to compute a route from the customer's specific location. Figure 12 shows a flowchart of the alternative embodiment of the "find your car" feature.

Figure 6 is a partial high-level functional diagram of entry kiosk 20 or 21, showing the functional elements of entry kiosk 20 and 21 that may be needed for the "find your car" feature. Kiosk 20 or 21 includes a camera 62, similar to camera 50, for capturing identification images of vehicles entering parking lot 10, a keyboard 64 at which a

customer types the license plate number of his/her vehicle, a display screen 66 for displaying responses such as shown in Figure 5 in response to the customer's inquiry, a printer 68 for printing access tickets, a reader 70 for reading access tickets and a transceiver 72 for communicating with customers' mobile devices. Components 62, 64, 66, 68, 70 and 5 72 are under the control of an entry kiosk controller 60 via a bus 74.

In another embodiment, the customer's smart phone location-awareness can be used to compute a route to the parking space from the customer's current location. With a precise location-aware system, such as a location-aware system based on WiFi time-difference-of-arrival, the customer can be directed with turn-by-turn directions, or through 10 an updating, homing-beacon process.

#### Tiered Parking Control

Under the tiered parking control scheme, the cost of parking varies depending on the location of each individual parking space 15. The present invention records the license plate of a vehicle on entrance to the car park, using a camera in the relevant entry kiosk 20 or 21, and reconciles the ticket with the license plate number captured at the individual parking space 15 by camera unit 16. Alternatively, the individual space number is reconciled with the license plate under a pay by space format. Finally, the customer may attach a prepayment to the customer's license plate number, and the system can automatically bill the customer for the exact space the customer parks in. This method 20 allows billing of customers for use of a specific parking space at a specific time without requiring any form of physical access control such as barrier gates, ticket or credit card payment terminals. Following reconciliation on system back-end software, a tariff is charged based on the location of the parking space at the automated pay station of the garage. This enables differential pricing to be efficiently varied based on the location, type 25 or demand down to the individual space of the car park. Alternately, this could be varied by amount of time spent in car park, number of previous times a vehicle has been parked, etc

#### Permit Parking Control

Detection algorithms in the system software are capable of identifying permit 30 badges to ensure that parking spaces that are allocated for permit use are occupied by authorised permit holder only. If a permit is not displayed, the system takes a picture of the vehicle for infringement processing. Parking garage management need no longer allocate a nested staff area; simply create a designated area and staff will be notified if they park



outside this area. In an alternative embodiment, permit parking can be allocated by license plate, or unique combination of vehicle make, model, color, and other identifying marks.

#### Parking Lot Lighting and Ventilation System Efficiency Enhancement

This system enables all parking slots **15** to be surveyed in real time. The illumination of slots and driveways can be controlled according to real time usage of each parking space **15**. As a result, lighting levels can be changed for individual spaces, zones or floors, *e.g.* via differential control of lighting fixtures **24**, leading to energy power savings. Furthermore, the same is true for ventilation systems whose power output and usage levels can automatically be adjusted based on individual parking space **15** utilization *e.g.* via differential control of ventilation vents **23**.

#### Customer “Profiling”

Different types of cars may correlate to different types of fee structures. Furthermore, different types of vehicles, such as hybrids, vehicles with permits, or vehicles subject to manufacture promotions, may be allowed to park in individual spaces **15** at a discount or premium. The detection algorithms are able to correlate the type of car to the promotion, discount or incentive. Furthermore, vehicle identification can be linked to customer loyalty rewards programs, allowing operators to provide shopping incentives at the point of parking. More details of such loyalty programs are provided below.

#### Enforcement

The system can track in real time whether a particular parking space **15** is correctly occupied, for every parking space **15**, 24 hours a day. If a vehicle stays longer than the proscribed length of time, enforcement action can be taken automatically using vehicle identification information (*e.g.* license plate) or manually by alerting enforcement personnel. Other infractions to parking rules and regulations, such as a single vehicle occupying more than one space **15**, can also be detected and acted upon.

#### Object Type Detection

Via image processing algorithms run either in camera units **16** or in row controllers **42** or in system controller **44**, the system can monitor the type of object that is parked in a space **15**. This can identify the make and model of a vehicle, and also tell if the item parked in the space **15** is a motorcycle, parking cart or a person. This can be used to notify the parking lot manager that the parking cart needs to be removed, that someone is loitering in the parking lot, or other such uses.

## Security

The image processing algorithms are capable of detecting other types of events, including suspicious activity that might indicate a theft in progress or a physical attack on a customer. This information can be sent to security personnel for immediate action, thereby  
5 improving the accuracy and coverage of existing closed circuit camera systems and other security measures already in place.

## Remote Monitoring and Control

System controller **44** can be connected to the Internet, as shown in Figure 2, enabling a large-scale system for real-time monitoring and control of any parking lot **10** from anywhere in the world. This can be achieved through a client-server architecture that combines software running on a remote computer, Internet-based communications, and server software running on system controller **44**. In the following discussion, the term “server” refers to server software running on system controller **44**. This remote monitoring system can be used for the following purposes:

- 15 • Remote monitoring of parking spaces **15** for security and enforcement.
- To improve the accuracy of the automatic detection through human intervention.
- As an input to the automatic detection algorithm, to refine the computer vision models by correcting errors and providing new labeled data.
- To identify system faults such as broken cameras **50**, **62** and take corrective action.

20 In one embodiment of this system, system controller **44** keeps a copy of a thumbnail image from each camera **50** on the site. When any of the following three actions are triggered, system controller **44** requests an image from the associated camera unit **16** and places it into a server-side cache located on the system controller **44**:

- 25 a) The camera module **16** notifies the system controller **44** that an entry/exit was detected by sending a Visit Event.
- b) The camera module **16** notifies the server that camera module **16** image has changed by sending a Change Detected Event.
- c) The system controller **44** cached copy of the thumbnail is greater than 10 minutes old.

30 The parking lot manager interfaces with the system through a web browser, opened to a web page that is served up by system controller **44** using a combination of HTML and JavaScript. An example of the web page user interface is shown in Figure 7. In this

overview monitoring system, the parking lot manager selects one or more zones that s/he wishes to monitor. A zone is a group of bays **15**, usually an entire level of parking spaces.

5 Every 10 seconds, a periodic task running in the web browser client queries a JSON webservice on the system controller **44** that returns the list of all bays **15** in the selected zones. The response includes a timestamp of each of the server's thumbnails. If the client's copy of the thumbnail is out of date (or it has never been downloaded) the client downloads the thumbnail from the server and inserts the thumbnail onto the page.

10 The page is split into 4 buckets. In each bucket, there is a grid of the thumbnails belonging to that category. The manager can click on any images associated with incorrect detection decisions to toggle the override mode of a camera unit **16**. If the camera unit **16** is in automatic mode, a mouse click forces it to the opposite detection decision. If the camera unit **16** has been forced into an overridden state, a mouse click puts the camera unit **16** back into automatic mode. Based on its next detection decision, the camera unit **16** will go to the VACANT or OCCUPIED state in automatic mode.

15 The following table shows how the manager corrects erroneous detection decisions.

State	New State	Why the user should click
VACANT in automatic detection mode	FORCE_OCCUPIED	There is a vehicle visible in the image that was not being detected by the algorithm
FORCE_VACANT (override active)	Automatic mode	There is a vehicle visible and the camera module <b>16</b> had been forced into a vacant mode. The click puts the camera module <b>16</b> into automatic mode and it goes into VACANT or OCCUPIED in automatic mode based on the outcome of the detection algorithm's decision
OCCUPIED in automatic detection mode	FORCE_VACANT	There is no vehicle in the image, and it is being detected as occupied by the algorithm
FORCE_OCCUPIED	Automatic mode	There is no vehicle in the image but the camera module <b>16</b> had been forced into a OCCUPIED mode. The click puts the camera module <b>16</b> into automatic mode and it goes into VACANT or OCCUPIED in automatic mode based on the outcome of the detection algorithm's decision

Of course, such correction of erroneous detection decisions also can be done locally, directly at system controller **44**.

The decision space of the grid can be expanded to allow error correction and model update for other types of decisions, such as vehicle make, color, vandalism, etc.

In an alternate embodiment, the system is further optimized for allowing human intervention for correcting errors and updating models, either off-line or in real-time. In this case, human intervention to correct detection mistakes and label data takes the form of a simple web-based game, as depicted in Figure 8. The human operator is presented with two grids of up to 9 images each. In the grid on the left, thumbnails are displayed of bays **15** that the vision algorithms have labelled as being occupied. Similarly, on the right are thumbnails of bays **15** that the algorithm has labelled as vacant. The human operator must click on any mislabeled data on the screen before submitting the changes to the server. A

30 second timer and the tracking of how many corrections have been made can be used to incentivize the operator to make many corrections as fast as s/he can.

As this preferably is a distributed system allowing many simultaneous operators to label the data, the server must decide which images are being allocated to users. The server maintains a priority queue, and a client request for images returns a block of images with the highest priority. These images are immediately removed from the priority queue to ensure that each user is getting a unique set of images. Each of the following criteria adds to the image's priority score, with the highest scores denoting the images with the highest priority:

1. The camera module **16** detected a significant change in its image.
2. The camera module **16** is currently overridden.
3. This parking space has previously been marked as incorrect (for spaces with recurring errors).
4. The algorithm's detection confidence is low.
5. This space has not been "watched" for more than 20 minutes.

Figure 9 is a high-level partial block diagram of an embodiment of a system controller **44** that is configured to support such interactive correction of the parking space occupancy detection algorithm. This system controller **44** includes a non-volatile memory **76** such as a hard disk or a flash disk, a processor **78**, a display device **80** such as a display screen, and a manual input device **82** such as a keyboard or a mouse, all communicating with each other via a bus **84**. This system controller **44** also is coupled, usually indirectly (as indicated by the dashed arrows), to camera units **16** to receive occupancy images of parking spaces **15**. Non-volatile memory **76** is used to store executable code **77** for classifying the occupancy images as occupied or vacant, for displaying these classifications on display device **80**, for receiving corrections of these classifications via manual input device **82**, and for modifying the classification algorithm in response to the corrections to make the classification algorithm more accurate, as described above.

Non-volatile memory **76** is an example of a computer-readable storage medium bearing code for classifying occupancy images, for interactively correcting these classifications and for modifying the classification algorithm.

#### Efficient Mapping of Sensor Locations

To enable any method that requires knowledge of the location in a parking lot **10** of a specific parking space **15**, we need a method for mapping each camera unit **16** to the

specific parking bay or bays **15** that the camera unit **16** monitors. The naïve approach is to manually record the unique address (MAC, IP, etc) of the corresponding camera unit **16** for each bay **15**, along with the bay's unique number. These numbers can be linked and cross-referenced in a table or a database. In addition, the bay locations can be manually marked  
5 on a map image of parking lot **10**, for use in helping customers find their cars, or for providing a pictorial view of the parking lot occupancy status to the parking lot manager.

Unfortunately, the process of manually recording and associating parking bays **15** with camera units **16** is extremely time consuming, costly, and error prone. Moreover, if the physical layout changes at any time during the life of the system – for example, if a  
10 camera unit **16** is replaced, or if the bay locations are changed – the associations must be manually updated to ensure the mappings remain accurate.

A better method is to use automatic discovery of the network topology to simplify the process of mapping bays **15** to camera units **16** in software. The system can use any of a number of automatic topology discovery algorithms to identify and map the topology of the  
15 network of camera units **16**, including the Packet Decoding Method described above for serial communications, the Server Initiated Topology Discovery and Sorting Algorithm described above for Ethernet communications, the Sensor Initiated Topology Discovery Algorithm described above for Ethernet communications, or any of a number of protocols known in the art, such as the Spanning Tree algorithm used by the Simple Network  
20 Management Protocol (Internet Engineering Task Force RFC 3411 — An Architecture for Describing Simple Network Management Protocol (SNMP) Management Frameworks).

Once the network topology is known, mapping bays **15** in a map image and associating them with camera units **16** is simply a matter of associating just one camera unit **16** of each string of camera units, as recorded in the network topology, with the  
25 intended map coordinates of that camera unit **16** and of the bay(s) **15** that that camera unit **16** monitors. Because system controller **44** knows the network topology and also knows the map coordinates of all camera units **16** and of all the other bays **15**, system controller **44** can associate all the remaining camera units **16** with their respective map coordinates and with the map coordinates of the bays that those camera units monitor. Figures 10A-  
30 10D are screen captures of a graphical user interface (GUI) that illustrate how this can be done simply in a single step, as follows:

1. User loads a map image of the parking lot, such as an engineering plan or other pictorial of the parking lot layout, into the GUI.

2. User marks the locations of the parking bays **15** by placing “bay pushpins” at the appropriate places in the image, as illustrated in Figure 10A. The software automatically saves the relative x- and y- coordinates in the image for each bay pushpin.
- 5 3. User marks the locations of camera units **16** by placing “camera pushpins” at the appropriate places in the image, as illustrated in Figure 10B. The software automatically saves the relative x- and y- coordinates in the image for each camera pushpin. Note that at this point the system knows the map coordinates of camera units **16** but does not yet know which camera unit **16** goes with which map  
10 coordinates.
4. User associates each bay pushpin with a camera pushpin by drawing a line from the bay pushpin to the camera pushpin, as illustrated in Figure 10C. A camera pushpin can be linked to multiple bay pushpins, but each bay pushpin can only be linked to a single camera pushpin.
- 15 5. User links the camera pushpins in a string by drawing a line to connect them, as illustrated in Figure 10C. A camera string corresponds to a physical string of camera units **16** daisy-chained together. A camera string begins at a “root node” attached directly to a row controller or an IP network switch, and terminates at an “end node” which is a camera unit **16** that has one empty communications port  
20 (either Serial or Ethernet switch).
6. User opens the Topology Discovery Tool window and finds the appropriate camera string, identified by the IP address of the row controller or Ethernet switch attached to its root node, as illustrated in Figure 10D.
7. User selects the camera pushpin corresponding to the camera string’s root node  
25 (this pushpin is shaded in Figure 10D), and presses Apply in the Topology Discovery Tool window. The software automatically links and cross-references the camera pushpins along the camera string with the physical MAC addresses of the camera units **16**, in order, according to the discovered network topology.
8. The user repeats this process for every physical string of camera units **16** in the  
30 parking lot.
9. If a camera unit **16** is ever replaced, the system can detect a change in the topology and automatically update the mapping to reflect the new change without requiring user intervention.

10. If bays 15 are ever moved or reconfigured or added or removed, or if camera units 16 are added or removed, the user can easily detect and correct the change using the GUI.

Figure 9 serves to illustrate a system controller 44 configured to map the locations of camera units 16 as described above, provided that executable code 77 is understood as executable code for implementing the mapping of the locations of camera units 16 as described above. Non-volatile memory 76 then is an example of a computer-readable storage medium bearing code for mapping the locations of camera units 16 as described above.

### Loyalty Programs

The information collected by the system can be used to enhance customer loyalty and shopping incentive programs by identifying customers automatically as soon as they park their car and notifying the customers and/or the merchants and/or the parking lot manager of qualifying loyalty rewards, shopping incentives, discounts, and other targeted programs. Customers can be notified directly in the parking space 15, or at any point between the garage entrance 30, 31 and the parking space 15, or at any point between the parking space 15 and the customer's ultimate destination such as a store, restaurant, or shopping area. Advertising can be in the form of audio and or visual signals, presented through one or more audio speakers and/or one or more video displays that are integrated with the system or that can communicate with system controller 44, and/or with row controllers 42, and/or with camera units 16. This can be achieved as follows:

1. Customer parks car in a parking space 15.
2. A camera unit 16 detects a car and sends an image of the car to system controller 44.
3. System controller 44 extracts the license plate number from image acquired by camera unit 16 and compares the extracted license plate number to a database maintained either on system controller 44 or on a server co-located on a network such as the Internet. Alternatively, the license plate could be extracted directly on the camera unit 16 and sent to system controller 44.
4. If a user record is found matching the recorded license plate, system controller 44 triggers a loyalty program event, which can include any or all of the following:
  - a. Offer audio and/or visual advertisements and/or shopping incentives and/or other loyalty rewards directly to the customer in the parking space 15,



through a speaker and/or video panel integrated into the camera unit **16** or external to it.

b. Send advertisements and/or shopping incentives and/or notification of other loyalty rewards directly to the customer via mobile phone.

5 c. Link discounts and other point-of-sale offers directly to the customer's loyalty account, which will be applied at point-of-sale when the customer uses his/her loyalty program card or a credit card associated with the account.

10 d. Notify stores in the shopping area that the customer is on-site, allowing the stores to offer qualified incentives, advertisements, and discounts directly to the customer.

### Advertising

The information collected by the system can be used to target advertising to specific demographics as soon as a customer parks his/her car. This can be done even without the use of license plate recognition and/or without consulting a user database, by examining demographic information such as make and model and color of the vehicle, license plate design, and other identifying marks such as bumper stickers and sports team insignias. Advertising can be presented to the customer directly in the parking space **15**, or at any point between the garage entrance **30, 31** and the parking space **15**, or at any point between the parking space **15** and the customer's ultimate destination such as a store, restaurant, or shopping area. Advertising can be in the form of audio and or visual signals, presented through one or more audio speakers and/or one or more video displays that are integrated with the system or that can communicate with system controller **44**, and/or with row controllers **42**, and/or with camera units **16**. This can be achieved as follows:

- 25 1. Customer parks car in a parking space **15**.
2. A camera unit **16** detects a car and sends an image of the car to system controller **44**.
3. System controller **44** extracts from the image anonymous demographic information such as: make/model/color of vehicle, license plate information, symbols and bumper stickers (such as sports teams, university, political affiliation, etc).
- 30 Alternatively, this information could be extracted directly in the camera unit **16** and sent to system controller **44**.

4. If demographic information is found, system controller 44 can offer audio and/or visual targeted advertisements directly to the customer in the parking space 15, through a speaker and/or video panel integrated into the camera unit 16 or external to it.

5

#### Valet Parking

The system can be used to simplify the process of valet parking for the valet operator, and enhance the valet parking experience for the customer. This can be achieved as follows:

1. Customer arrives at valet stand, receives a ticket with a unique i.d. number on it.  
10 Number can also be encoded in a bar code or QR code.
2. Valet parks car in a parking space 15.
3. A camera unit 16 detects the car and sends an image of the car to system controller 44.
4. System controller 44 extracts the license plate number from the image and  
15 automatically associates the license plate number with the ticket i.d. number. Valet can also manually associate the license plate number with the ticket i.d. number using a terminal or handheld portable device, or using a bar code reader. The license plate number could also be extracted directly by the camera unit 16.
5. Customer can surf to a website at any time to see a live image of his/her car to  
20 ensure that the car is safe. The website can be accessed from any web browser or through a smart phone application, or the URL of the website can be encoded into the QR code so that the customer can simply scan the QR code with his/her smart phone to open up the website to the appropriate page. The customer can manually enter his/her license plate number to locate and view the live image of his/her car.
- 25 6. The customer can enter his/her phone number or email address through the website or through a phone application to be automatically notified if the car moves.
7. The customer can use the website or the phone application to alert Valet that s/he is returning, so the valet has the car ready when s/he returns.
8. The valet simply enters the ticket i.d. number into the terminal or into a handheld  
30 device, or scans the bar code, or enters the license plate number, and the system tells the valet which parking space number is associated with that record, and may even display a map so that the valet can easily locate the vehicle.

### Renting Out Private Spaces

In a mixed-use (commercial + residential) facility, the system enables residents to rent out their spaces if/when they aren't using them. This can both increase the effective capacity of a commercial parking garage, and provide a monetary incentive or subsidy to residents. This can be achieved as follows:

1. When a resident signs a lease or purchases a parking space or purchases a residential or commercial unit, s/he get an online account associated with his/her parking space(s) **15**.
2. A resident can log on to an online system to access and manage his/her account.
- 10 3. A resident can configure his/her account with his/her license plate number, phone number, email address, and any other identifying information.
4. A resident can configure the system to automatically notify him/her if a car with an unknown license plate parks in his/her space **15**.
5. A resident can opt-in to a system that allows his/her space **15** to be used by visitors to the commercial entities that share the parking lot **10**. This can be 24 hours/day, or for fixed time periods and/or specified days of the week/month/year. This can also be configured in the online system, or by phone or at a kiosk or in person with the parking manager.
- 15 6. If a visitor parks in the resident's space **15** during the designated times, the resident either receives a percentage of the parking revenue, or a share of the facility's revenue calculated as a percentage of the revenue collected from the entire pool of shared private spaces. Money can be disbursed as a credit against rent, or directly as a deposit into the resident's bank account, check, money order, cash, PayPal™, etc.
- 20

### Individual Security Monitoring

25 When parking a car, particularly in a public parking lot, safety and security of the vehicle is a major concern for many people. The system can be used to provide an extra measure of security by allowing customers to monitor their vehicles directly, as follows:

1. Customer loads a smart phone application, or navigates a web browser to a particular web site, or sends a text message to a particular phone number, and enters the unique identification number printed on the access ticket received upon entry to the parking lot **10**.
- 30

2. System controller **44** receives request, queries its database for the vehicle record, and responds with a live or recent (*e.g.* within the past 5 minutes) image of the vehicle in the parking space **15**.

3. Customer can configure the system, through the web site or phone application or via text message commands, to automatically alert the customer via text message and/or email if any of the following occurs:

a. The image captured by camera unit **16** of parking space **15** has changed compared to a previously captured image; this could indicate an attempt to vandalize or break into the vehicle.

b. The parking space **15** has become vacant; this could indicate a possible theft of the vehicle.

It will be appreciated that many variations, modifications and other applications of the described embodiments may be made. Therefore, the claimed invention as recited in the claims that follow is not limited to the embodiments described herein.

## Claims

1. A method of managing a plurality of parking spaces, comprising:
  - (a) monitoring a parking space with an imaging device of an imaging unit
  - (b) detecting, by said imaging unit, occupancy of said parking space;
  - 5 (c) assigning said parking space, in which said occupancy was detected, an occupied status;
  - (d) obtaining, as a result of said parking space having said occupied status, a single high resolution image of a vehicle occupying said parking space, said high resolution image obtained by said imaging device;
  - 10 (e) storing at least part of said high resolution image;
  - (f) charging a differential tariff based on a location of said parking space to an owner of said vehicle occupying said parking space;
  - (g) processing said high resolution image to extract a vehicle identifier of said vehicle from said high resolution image; and
  - 15 (h) in response to an inquiry, by a customer, that includes vehicle information entered in the form of one of a keyed in licence plate number or a keyed in make or color of vehicle or an encoded vehicle licence plate number read from a receipt or access ticket and wherein said vehicle information is entered to permit comparison by a system controller:
    - 20 (1) having the system controller compare said entered vehicle information to said vehicle identifier extracted from said high resolution image obtained by said imaging device;
    - (2) identifying a location of said parking space based on a known location of said imaging device that obtained said high resolution image, and
    - 25 (3) directing said customer to said parking space.
2. The method of claim 1, further comprising:
  - (i) issuing to said customer, prior to parking said vehicle, a receipt that
  - 30 includes said vehicle information.
  - (j) detecting, by said imaging device, vacancy of said parking space; and
  - (k) assigning said parking space vacant status.

3. The method of claim 1, wherein said assigning of said occupied status further comprising:

    sending a notification from said imaging unit to a system processor indicating that said parking space is occupied; and

5       sending a request from said system processor to said imaging unit to capture said high resolution image of said vehicle in said parking space.

4. The method of claim 1, wherein said vehicle identifier includes at least one of: a license number of said vehicle and at least partial visual characterization of said vehicle.

10

5. The method of claim 1, wherein said directing includes displaying a map showing a route to said parking space.

6. The method of claim 1, wherein said directing includes issuing a plurality of navigation instructions to said customer.

15

7. The method of claim 1, further comprising:  
    displaying a thumbnail image of said parking space on a graphic user interface “GUI”;

20       deciding whether said occupied status is incorrect, based on a visual review of said thumbnail image on said GUI; and

    correcting said occupied status if said parking space shown in said thumbnail image is vacant.

25 8. The method of claim 1, wherein said monitoring of said parking space comprises:  
    (i) obtaining multiple images per second; and

    (ii) running each of said multiple images through a classification algorithm to determine whether said parking space is occupied;

30       wherein said detecting occupancy of said parking space includes recognizing, by said classification algorithm, occupancy of said parking space.

9. The method of claim 1, further comprising the step of:  
    obtaining multiple images per second; and

running a change detection algorithm on said multiple images to determine whether an event has occurred in said parking space, said event selected from the group including: arrival of said vehicle in said parking space and departure of said vehicle from said parking space;

5            wherein said detecting occupancy of said parking space includes said change detection algorithm determining said arrival of said vehicle in said parking space.

10.        A system for managing a plurality of parking spaces, the system as substantially hereinbefore described with reference to FIGs. 2 to 12 of the accompanying drawings.

10

11.        A method of managing a plurality of parking spaces, the method as substantially hereinbefore described with reference to FIGs. 2 to 12 of the accompanying drawings.

